

ASSEMBLY, INSTALLATION AND OWNER'S MANUAL FOR SNORKEL HOT TUBS, STOVES AND ACCESSORIES



Congratulations! You are the owner of one of the world's most enjoyable hot tubs. With proper care it will provide years of enjoyment.

Each site and installation is unique. Individual owners have their own ideas for their hot tub site and should plan their installation accordingly. This booklet will provide some suggestions that we hope will make your installation safe, convenient, and pleasurable. Our thanks to the hundreds of owners who have responded to our surveys and questionnaires. Many of their ideas and comments are incorporated within this manual.

Contents

| | |
|---|----|
| GENERAL INSTALLATION INFORMATION | 2 |
| INSTALLATION OVERVIEW | 2 |
| INDOOR INSTALLATIONS | 4 |
| FOUNDATIONS | 4 |
| HOT TUB ASSEMBLY | 7 |
| DRAIN KIT INSTALLATION | 9 |
| ASSEMBLING THE HOOPS | 11 |
| STANDING THE STAVES | 13 |
| INSTALLING THE HOOPS..... | 18 |
| ROUNDING THE TUB | 21 |
| STOVES AND ACCESSORY PLACEMENT | 24 |
| BENCHES | 25 |
| SNORKEL AND SCUBA STOVE INSTALLATION | 26 |
| FENCE ASSEMBLY AND INSTALLATION | 28 |
| DOOR HANDLE AND STOVE PIPE INSTALLATION | 30 |
| INSTALLING JET SYSTEM AND POWER PAK PLUMBING | 34 |
| INSTALLING FILTER PAK (PUMP & FILTER ONLY) | 37 |
| INSTALLING ELECTRIC/GAS SYSTEM (POWER PAK) | 39 |
| FILLING AND SEALING THE TUB | 39 |
| SANITATION & JAPANESE STYLE BATHING | 41 |
| MAINTENANCE | 42 |
| WOOD AND ALUMINUM COVER ASSEMBLY | 44 |
| SNORKEL AND SCUBA HEATER OPERATING INSTRUCTIONS | 45 |
| STOVE MAINTENANCE | 47 |
| EXTERIOR AND FENCE SHELF ASSEMBLY | 50 |
| BOX STEP AND STAIR KIT ASSEMBLY | 51 |
| WARRANTY | 52 |

Please note: At this time we are transitioning from supplying stainless hoops (made of stainless rod) to stainless flat band as they are easier to install and to package and ship. Accordingly, you may receive either flat stainless band or the round hoops for your tub. Please call us if you have questions.

GENERAL INSTALLATION INFORMATION

Thank you for choosing Snorkel Hot Tubs. Your tub should provide you with many years of enjoyment. Please read all portions of this assembly manual pertinent to your installation before starting assembly. It will speed the process and minimize problems. Pages 4-6 offer suggestions for general site planning if you haven't already created your own design. If you have any questions after reading the manual, please call us. We're happy to help. **IF YOU HAVE PURCHASED ONE OF OUR GAS OR ELECTRICALLY HEATED POWER PAK SYSTEMS, THE CONNECTIONS TO THE GAS SUPPLY AND/OR TO THE ELECTRICAL PANEL MUST BE DONE BY A QUALIFIED PROFESSIONAL.** Improperly connected electrical systems can cause fatal electrical shock and leaking gas is highly explosive. Check and follow your local building codes concerning installation of hot tubs and wood-burning heaters. Familiarize yourself thoroughly with the instructions, terms and suggestions. Most of the calls to our tech support staff are from customers who haven't reviewed their manual thoroughly.

ON LINE VIDEO AIDS

We have published a series of 13 videos of the complete assembly process on YouTube. They can be viewed at https://www.youtube.com/channel/UCS_6v6I9qiLqrekbq5zhYBA/playlists. These 13 videos will be referenced at the appropriate places throughout the manual by a QR code as shown below. You can use your smart phone equipped with a QR reader app to read the QR code and it will bring up the appropriate video segment for the portion of the assembly manual you are at to provide a visual demonstration. This can be especially useful when you are actually doing the assembly and need a refresher or if something is unclear.



QR Code for Snorkel Hot Tubs You Tube Playlists

INSTALLATION OVERVIEW

One of the most important installation decisions is deciding where to locate your hot tub. When well placed, a tub is more enjoyable and easier to operate. Factors to consider are esthetic values, exposure, wind, safety, convenience, ability of site to safely handle weight of full tub, hose and water locations, electric or gas service availability, and privacy.

If you are locating the tub near the house, a location close to the bedroom and bathrooms is generally the most convenient. Bathrooms, with showers, towels and bath mats, can be a natural changing and drying off area. Having the tub close to your bedroom is also nice. After enjoying a night-time soak, it is wonderful to crawl out of the tub and roll into bed.

Location with respect to privacy and scenic views should be considered. For most people, relative privacy is important for enjoying their tubbing experience. Accordingly, your tub should be placed where passersby and neighbors are not in your line of sight. Natural screens of trees and shrubs can maintain privacy while providing scenic views.

Other considerations include the relative location of the stove and drain. Each tub site presents unique circumstances that may determine where the stove and drain should be positioned. With

regard to the stove, you will want to have your wood supply relatively close by and have easy access to the stove door to feed the fire. You will also want the stove located so that its fence and chimney stack don't block your view. The bench locations and their relative heights should also take into account your views. If your installation is in a place where leaking water would damage the area, please build a watertight frame to catch any overflow water or any leaking from the initial sealing process.

At the same time, you will want to locate the drain so that you have easy access to connect and disconnect a hose if you are using one to drain water away from the tub site. You will also want to orient the tub bottom so that the drain, when positioned properly, will be located in the area just behind the fence where the stove is placed. This will keep people from accidentally dislodging the drain plug. However, you want to be careful not to locate the drain under the stove as it will be impossible to remove the plug.

Please consider the placement of every item you plan to install before you actually begin the installation. Each item can have an effect on other items you plan to install. One simple approach to make sure you have everything planned properly is to lay out the chime joists, place the bottom on the chime joists (with bottom boards perpendicular to the joists). Then simply place the stove and benches (if you are using them) on the tub bottom and see if the relative positions of the stove, drain, and benches are appropriate for the site and your needs.

Note that in the figure below the drain kit is shown on the bather side of the fence only for purposes of illustration. As mentioned above, putting it just on the other side of the fence will reduce the chance of the drain plug being accidentally dislodged.

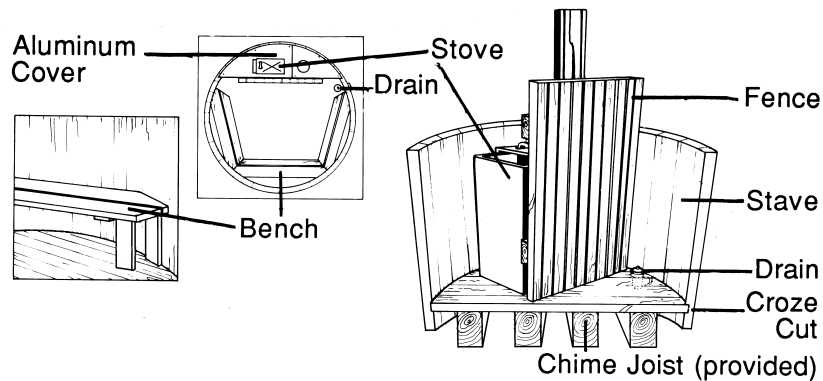

Once placement has been determined, and the tub assembled, we recommend installing accessories in the order outlined below. The drain kit will be installed before the tub is assembled.

1. Stove
2. Benches
3. Aluminum cover or other cover
4. Jet System, Filter System, Electric or Gas Heating System

Again, give some thought to these items as you plan your installation and then refer to the detailed instructions provided for each item.

INDOOR INSTALLATIONS

Hot tubs installed indoors will greatly increase the humidity in the home. This can be beneficial in a greenhouse. However, in homes, this may cause damage if the humidity is not adequately vented to the outside. Excessive humidity will cause mildew and may damage interior wall and ceiling materials. Please make sure that the humidity is properly vented to the outside and controlled. Consult an HVAC specialist if you have any doubts.

Also, you will need to provide some means of draining the tub. A floor drain is best as it also provides a drain for overflow, splashing, etc.

Indoor Chimney Installation

When a chimney passes through a ceiling or roof, or if it is close to a combustible surface such as a building wall or fence, insulated chimney sections must be used. Virtually all building codes require an insulated chimney in these situations. Even if you are not subject to codes in your area, it is essential to use insulated chimney sections for proper safety. Stack temperatures can get as hot as any wood stove, and un-insulated chimney sections can set fire to nearby combustible material. If you are unfamiliar with these chimneys or when they should be used, first determine what your local building code requires, then, call us or contact your local hardware store or wood stove dealer for information.

FOUNDATIONS

Hot tubs may be supported in a variety of ways. The most important thing to consider is adequate support; a tub full of water will weigh from 2,000 to over 10,000 pounds (see specifications chart below for the weight of your tub).

Types of supports commonly used include posts, piers, concrete blocks, cement slabs, beams or railroad ties. Concrete slabs (at least 4. thick) reinforced with wire mesh provide the most permanent and secure foundation and are recommended where practical. Most other foundations can be prone to uneven settling which may cause the tub to leak. There is a wealth of information on patio design online. Remember, your foundation needs to be able to support the weight of your tub.

| HOT TUB SPECIFICATIONS CHART | | |
|------------------------------|---------|--------|
| Tub Size | Gallons | Weight |
| 4' x 3' | 190 | 1870 |
| 4' x 4' | 282 | 2655 |
| 5' x 3' | 315 | 3010 |
| 5' x 4' | 463 | 4230 |
| 6' x 3' | 470 | 4380 |
| 6' x 4' | 680 | 6150 |
| 7' x 3' | 660 | 6000 |
| 7' x 4' | 950 | 8390 |

These figures are approximate and should be used only as a guide.

Some tubs are placed on existing grade; some are dug down and sunk in the ground. Others are set on decks or trestles to elevate them. In every case, but especially with tubs sunk below grade, it is important to allow for ventilation under the bottom and around the sides. Good drainage is required to prevent the tub from sitting on damp earth or in water, which can cause it to rot. It is important that draining water or overflow does not splash dirt up on the tub. A good approach is to line the hole with plastic sheet or similar barrier that will prevent the earth from splashing on the tub. The acids in the earth can cause the tub to rot.. A good rule is to allow at least 12" of clearance from the earth around the sides and a minimum of 6" under the bottom boards. If you are going to put the tub on a deck, you should be aware that most decks are not designed to support the loads created by a hot tub. Consult a structural engineer or contractor to determine the best way to ensure an adequate design for your deck.

Many people like the idea of having the tub inset into the deck both for aesthetic reasons and ease of access. Tubs inset into a deck are an attractive installation alternative. However, if you inset the tub into the deck or set the tub below grade and are heating your tub with a Snorkel Stove® or Scuba Stove® you should build a sturdy barrier to prevent accidental contact with the hot stove and/or chimney pipe. Alternatively, the stove should be positioned in such a manner (e.g. at the edge of the deck) so that accidental contact is not possible.

With on grade installations, the tub rim is about 36" - 48" above grade and acts as a natural barrier or fence to help prevent someone outside the tub from stumbling or falling against the hot chimney pipe or stove. When a tub is inset into a deck, an accidental stumble or fall can more easily result in contact with the chimney pipe, possibly producing a severe burn. Children could be particularly susceptible to this situation.

An additional consideration when inseting a tub into the deck is to allow for future access to the tub. Older tubs can start to develop minor leaks as the wood loses some of its natural resiliency. If leaks of this nature occur, they can usually be dealt with by tightening the hoops or, if necessary, reseating the staves by hammering on them with the mallet while tightening the hoops. Either approach, but especially the latter requires some degree of access to the tub.

The illustration below shows a tub on a concrete pad, the most stable and, if suitable in your instance, the best base for a tub. Whenever, making a base on ground for the tub, make sure to extend the base at least a foot beyond the perimeter of the tub to keep dirt and its acids from splashing up on the tub.

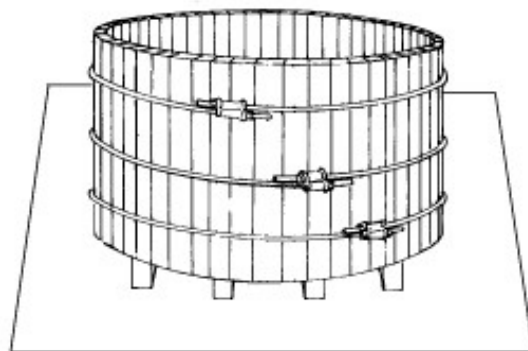

Once your site is prepared, you will place the chime joists and begin assembly. Your hot tub will sit on its 4. x 6. chime joists (provided) which run perpendicular to the bottom boards of the tub.

For a basic installation without concrete pad, frame an area with pressure treated beams or railroad ties, dig out the area and fill with 5/8" (5/8" or less in size) crushed rock - usually available at Home Depot or lawn and garden store. This material packs nicely and doesn't shift as much as a more rounded river rock or pea gravel. For a more foot friendly surface, place pavers or medium river rock on top or the crushed rock once the tub is in place. Smaller pea gravel will stick to your feet and end up in the tub. When setting the 4 x 6 chime joists for your tub bottom make sure the are level and the upper faces are flat (in the same plane) so that tub will have a solid surface to rest on. The gravel bed should be large enough to absorb water overflow.

A popular approach is to dig the pit deep enough so that it can be used as a drainage bed. If you have a cement patio, place your supports directly on top of the cement slab. Consider any additions such as decking or steps for access to your tub now, and allow for placement of supports at this time.

HOT TUB ASSEMBLY

GETTING READY

Each step that requires action on your part will have a box for you to check as you complete this step of assembly. We hope this helps you.

Carefully unpack the tub. Inspect each piece to be sure there was no hidden damage that occurred during shipment. If you notice damaged parts that were not apparent when you first received your shipment, please call us immediately. We can help with any after the fact freight claim process and get your replacement parts on the way.

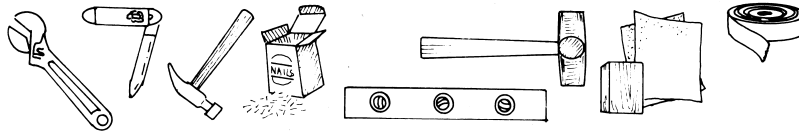

List of Tools Included and Items You Need to Supply

Snorkel Hot Tub Supplied Tools

- Ratcheting Box Wrench
- Heavy Rubber Mallet
- Caulking gun and caulk
- Anti-seize lube for hoop threads

Tools You Need to Supply

- Adjustable Crescent Wrench
- Knife/Utility knife
- Masking Tape
- Level
- Tape Measure
- Drill and 5/16" bit for stove and fence)
- Philips Head Screw Driver
- Hammer and medium/small nails
- Sand Paper

ROUND UP YOUR HELPERS

While one person can assemble a tub, it is more enjoyable, as well as quicker and more efficient if you have a few helper or two. Two people familiar with the instructions should be able to put the tub together in 4 - 6 hours.

CHIME JOIST PLACEMENT

Chime joists should be placed as shown in the diagram on the top of the following page. Be sure you use the proper guide for your size tub. Make sure that: 1) the chime joists will run perpendicular to the tub bottom boards; 2) the chime joists are set with the 4" side on the foundation (raising the tub 6" off the base) and that they are positioned so they will not interfere with the drain kit assembly. If you have a 5' tub with a drain kit, the standard placement of the outer chime joists, shown below, may interfere with the drain kit assembly. If necessary, move the appropriate chime joist 2 or 3 inches in towards the center joist to provide clearance for the drain kit.

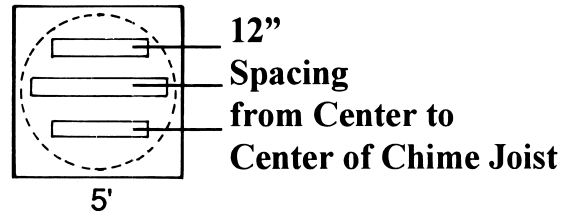
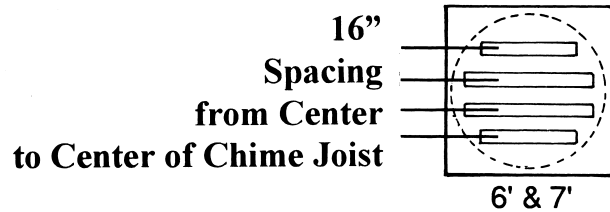

QR Code for Chime Joists and Bottom Assembly Video

TUB BOTTOM ASSEMBLY

- 1. Verify that your bottom is a matched set by comparing the marking on each half. Place the two bottom sections on top of the chime joists with the side that has “This Side Up” and the two concentric red lines around the perimeter of the bottom facing up. **Make sure that the floor boards are perpendicular to the chime joists so that all the floor boards are evenly supported.**
- 2. Align the tongues and grooves of the two opposing halves so they mesh with each other and then slide the two halves together as snugly as you can.
- 3. Nail the two (8” x 1 1/2” x 1/4”) wood strips (they are provided and are in the plastic bag with the hoop, lugs, etc. which are in the stove) across the center seam on the top face of the tub bottom (see image below). Do not pound nails in more than 3/4”. Offset the nails as shown to prevent cracking and provide more stability to the bottom boards. This is to ensure the two halves do not separate during the assembly process.

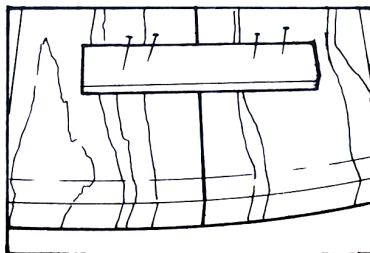

DRAIN KIT INSTALLATION

If you purchased our drain kit, this is the best point in the assembly to install it. The following pictures show how it fits into the pre-drilled hole in the tub bottom.

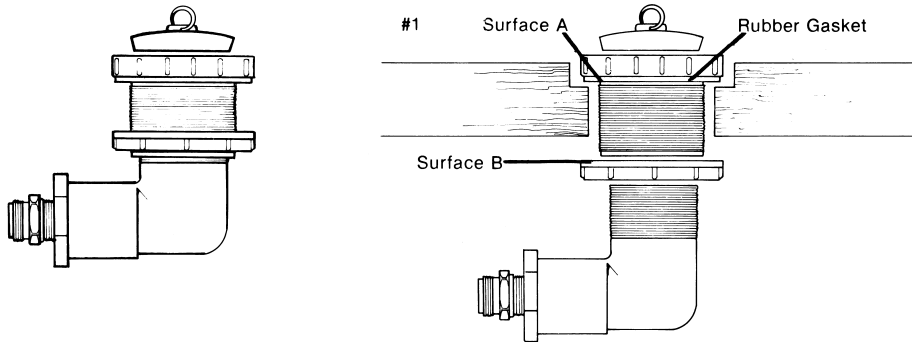

□ A. Remove nut, gasket, and 90° elbow from drain fitting. On the tub bottom apply a large bead of silicone to the recessed lip of the counter sunk hole. Then spread silicone sealant freely (using Snorkel Hot Tub supplied caulk and caulk gun) on surface A. (the underside of the grey fitting). Push the rubber gasket so it seats against the fitting and then apply silicone to the bottom of gasket, the side that contacts the drain hole cut in the tub. Insert fitting into hole from inside tub. Then apply a little silicone to surface B, the flat side of the plastic nut. Screw the nut snugly on the outside of the threaded end of fitting. Be careful not to cross thread or over tighten the nut. The tub will expand when it gets wet and may crack the fitting if over tightened.

□ B. Choose the drain fitting adapter you will be using: a reducer with brass adapter for garden hose or the straight PVC pipe for a vinyl drain line. Screw the threaded end of whichever adapter you will be using into the inside thread of the elbow and then thread into the drain fitting.

□ C. Install stopper on the inside of the tub. To prevent freeze-ups in the winter, make sure the drain line runs continuously downhill, so no water is left in the line.

□ 4. Place the bottom on the chime joists. Use a level to assure the bottom is level. If not, re-level the chime joists. Do not use shims between the chime joists and the tub bottom to level the bottom.

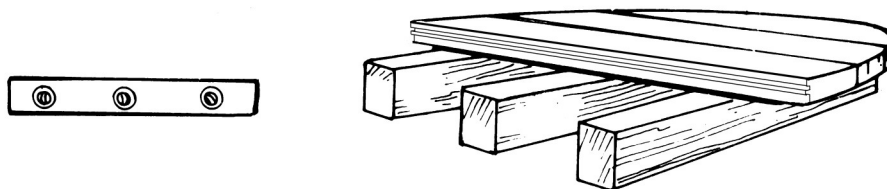

□ 5. Check to see that the bottom makes even contact with the chime joists and that the chime joists are level and contacting the foundation. If necessary use wood shims between the chime joists and the foundation to level them. When the bottom is in place, it should overhang the joists by at least 1 1/2" (more is O.K.). If necessary, adjust the bottom and/or chime joists slightly. This ensures that the weight of the tub will be borne by the bottom and not by the staves. Fine tuning the position of the bottom on the chimes is not critical at this point, as the bottom will move on the chime joists when standing the staves and will probably require a final adjustment later.

ASSEMBLING THE HOOPS/BANDS



QR Code for Hoop Assembly Video

HOOPS

Fitting the bottom hoop on the tub works easiest if you slide it up from the bottom. You only have about 5" to negotiate as opposed to almost 3' if you try to slide it down from the top. Accordingly, we recommend that you assemble the hoops at this point and place one on your base underneath the tub bottom. Then it is ready to slide up on the staves when you are done standing the staves.

If you purchase a tub with black iron hoops, you should protect the threads and nuts with some type of grease so that the threads won't rust. As the tub ages the wood will tend to shrink slightly and you will need to be able to tighten the hoops in the later years of the tubs life, typically starting around year 7 and every 3 or 4 years thereafter.

Each hoop is composed of two half rounds that are connected by a coupler nut which is used on the hoop ends with the short 2" of thread. The coupler nuts, along with the lugs and all related nuts and washers, are in the lug package.

- Lay two hoop pieces on the ground with two thread ends touching. Connect them by screwing the coupler nut all the way on one half of the hoop and then, with the other hoop half end touching, back the coupler nut onto the other hoop. Measure the exposed thread lengths on either side of the coupler nut to make sure the coupler nut is threaded on each hoop equally. Repeat for each hoop.
- Install the lug by inserting long threaded end of the hoop into the narrow end of the lug and out through the wider end of the lug (see drawing). Slide the washer on, then start threading on the nut. Thread the nut on 1/2" so that the hoops will fit loosely on over the top of the tub.

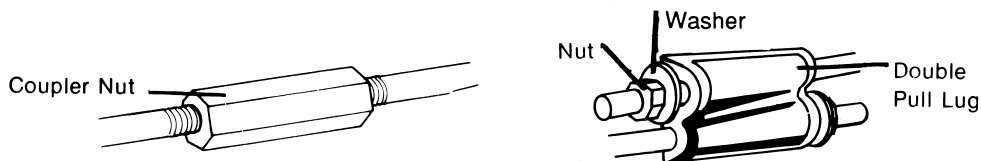

□ Apply lubricant on the threads through the back (open) side of the lug. This lube is critical for stainless hoops which can seize up and freeze in place under the pressure created from tightening. Make sure a good amount gets on the bottom hoop threads. This is the hoop that is going to be under the most tension.

□ **Double check to make sure your lug assembly matches the drawing.** Make sure the washers and nuts are on the larger ends of the lug. Occasionally, people get this reversed. If the washer starts to dig into the tub when tightening, you've inserted the hoop into the wrong end of the lug. Be careful to not cross thread the nuts.

BANDS

NOTE: WHEN HANDLING BANDS, PLEASE WEAR GLOVES. The edges are sharp and can cut your fingers.

Assembling the bands is a very easy process. Simply uncoil the band. The clamping lugs are already in place and the band is bent back to keep them in position.

Once the band is uncoiled and laying flat, insert the threaded rod through the tube of one lug and then through the tube on the opposing lug. Place a washer on each end of the threaded rod and then thread a nut on each end. You will want to thread the nut on just far enough so the threaded rod is flush with the end of the nut. This will give you the maximum of circumference in the band and make it easiest to slide over the staves.

STANDING THE STAVES

GENERAL INFORMATION

Each of the staves has a croze (or dado) cut that allows you to pressure fit it onto the tub bottom. It is a special dado cut made on a radius so that the stave will fit snugly against the rounded circumference of the tub bottom. As your tub wood has been kiln dried to about 8-10% residual moisture, it can absorb moisture from the air causing it to swell slightly. This sometimes causes some of the staves to fit excessively tight when trying to put them on the bottom. You don't want to force the staves on in this situation as it could cause the bottom of the stave to crack off. If you find that the croze seems too tight for the staves to tap easily onto the bottom, lightly shave or sand the bottom boards where necessary until you are able to tap the staves into place.

Putting the staves on the tub is a two stage process. When you initially stand the staves on the bottom, you will only put them part way onto the bottom, to the first red line, with a slight gap between the edges of the staves. After all the staves are on the tub, you will put the hoops on and begin tightening the hoops and tapping the staves, gradually drawing them in and removing the slack between the staves.

There are two red concentric circles drawn around the perimeter of the tub bottom. The outer circle is 1/4" away from the inner circle. This inner circle will be the true finished inside diameter once the staves are fully seated. When initially standing the staves, tap the staves just to the outer circle on the bottom. **DO NOT TAP THE STAVES TO THE INNER CIRCLE AT THIS TIME.**

Also, at this initial standing of the staves, do not try to seat them tight against each other. You want to leave a slight gap (about 1/32") between them (at the croze cut not the top). By putting them on only part way initially and then pulling them in later while tightening the hoops, you will eliminate the gaps between the staves. This process is designed to pull all the staves tightly together at the same time that the back of the croze cut is drawn snugly against the edge of the bottom.

It is okay if there is some variation in the size of the gap between the staves, but you don't want to have several staves in a row with large gaps (1/8" or greater) and then a similar amount in a row with no gaps between the staves. You want the gaps fairly evenly distributed around the perimeter of the tub so that they can easily be drawn in evenly.

When the staves are drawn on to the inner red line approximately 1 1/2" of total gap between the staves is removed. That may sound like a lot, but amounts to reducing only about 1/32" gap between each stave on a typical 6' tub, a little less on larger tubs with more staves and a little more on smaller tubs with fewer staves. Again, be sure to look at and gauge the gaps at the level of the croze cut, as that is the critical area, not at the top of the staves.

Understanding and executing this process will affect how quickly the tub will swell and seal itself. Fortunately, tubs are very forgiving and absolute perfection in assembly is not required. Our kiln-dried Western Red Cedar will swell anywhere from 2-4% (4" - 9" around a 6' diameter tub) when wet and is capable of eliminating a number of minor flaws in assembly. However, that does not mean you can have a gap of 1" and expect it to seal, as there is a limit to how far the staves can move freely when seated and bound. Accordingly, you should have no more than a few gaps of 1/32 - 1/16" between staves once the tub is assembled.

The table below shows the number of full staves and key staves for each tub diameter.

| Tub Diameter | # of Full Staves | # of Key Staves | Tub Diameter | # of Full Staves | # of Key Staves |
|--------------|------------------|-----------------|--------------|------------------|-----------------|
| 4' | 27 | 2 | 7' | 48 | 2 |
| 5' | 34 | 2 | 8' | 55 | 2 |
| 6' | 41 | 2 | | | |

GET STARTED



QR Code for Stacking and Standing the Staves Video

- 1. Sort through the staves and locate the four staves marked with chalk lines on the outside and the two key staves. The key staves are those that have one flat side with a tongue or groove on the opposing side. Set the marked staves and key staves aside.

The chalked lines on the four marked staves indicate the height at which each hoop is placed. You want to place these marked staves at roughly equal distances around the tub to aid in hoop placement around the tub.

The key staves are used to fit in the gap for the last stave. Generally, it is easier to assemble a tub using two key staves with opposing flat surfaces rather than trying to nest in a full tongue and groove stave into that gap, particularly if it is a tight fit. Accordingly, we have provided two appropriately size key staves to fit in the final gap when standing the staves.

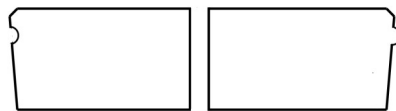

Key Staves

- 2. We find it convenient to stack all the staves on top of the tub bottom, croze (groove) side up as shown. The weight of the staves will help keep the bottom in place as you work.

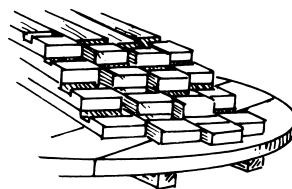

□ 3. Using your provided Snorkel Hot Tub rubber mallet, erect the first stave (starting with a chalk-line marked stave is a good idea). **This stave must be centered over the seam between the two halves of the tub bottom.** Make sure the croze engages both boards.

□ 4. **Please read this whole step before proceeding.** Put on all the full width staves first - with each stave nesting against the preceding stave - by **tapping each onto the outside red line** on the tub bottom. It generally works best if you try to engage the tongue in the neighboring stave's groove before trying to tap it on. As you work your way around the tub use tape (blue masking tape works best) to hold the staves together. The tape is extremely useful in helping keep the staves upright on the tub when you are trying to nudge a stave sideways with the mallet. Without it, they will tend to fall off.

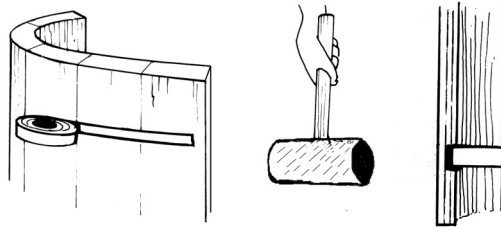

As you stand the staves, distribute the four chalk marked staves evenly around the perimeter of the tub. The staves should be just barely touching one another with just slight gaps in between. Small 1/32" gaps (credit card thickness) at the croze cut are perfect for a 6' diameter tub, a little more for a 5' tub and a little less for a 7' tub. Again, the concept is to have the staves drawn in tight once they are moved to the inside red line, not on the initial placement. Every four or five staves that you place, check back to make sure that none of the previous staves are being shoved off, and that they are still lined up correctly against the outer red circular line.

The tops of the staves may tend to flop apart, which is fine. Use masking tape as needed around the tops of the staves to help keep them in place, making it easier to slide the hoops over the top of the tub.

The fit at the bottom (croze cut level) is the critical area to focus on. Don't be concerned with how close or far apart the staves are further up. Ideally, there would be an equal gap between each stave at the bottom, but reasonably close works here. **It is important, however, that you do try to have the inter-stave gaps evenly distributed around the tub so that when the hoops are placed and tightened the staves can be drawn in evenly.** You do not want (to take an extreme example) to have the staves on one half of the tub with the staves perfectly tight against each other and the staves on the other half with 1/16" to 1/8" gaps.

□ 5. Check the tub floor for a gap between the two halves as you proceed. The two tack strips should hold the bottom halves in place, but pounding staves on can create a gap. Any gap between the two halves should be 1/8" or less when finished standing the staves. Use your mallet to move the staves into alignment as you proceed standing them around the tub. At this step, the staves should nest fairly close together with roughly equal inter-stave gaps between them where they join the floor. When you begin to tighten the hoops, you'll hammer with the mallet to seat the staves all the way onto the tub bottom.

THE KEY STAVES

After standing all the full width staves, you will fit in the key staves. Make sure that you've taped the tops of the adjacent staves together to avoid pushing them off the tub bottom when inserting the key staves. The key staves are installed with their flat edges pressed tightly together with their tongue and groove on the outside. The two key staves provided should fit snugly into the remaining gap. If there is excess remaining space, the other staves are too tight together. If the key staves are too tight or won't fit at all, there is too much inter-stave gap between the full width staves.

There are 3 basic scenarios you could encounter when fitting in the key staves:

1. The key staves are a perfect fit, fitting snugly in their gap. Congratulations, you are good to go on to the next stage, putting on the hoops.
2. The gap for the key staves is too wide for the key staves to fit snugly. That is, there is a gap of 1/8" or more on either side of the key staves. See Fix #1 below.
3. The gap is too narrow for the key staves to fit. See Fix #2 below. Note that if all the staves and their gaps look good (about 1/32" - 1/16"), but the key staves still fit tightly, it seems to work best to tightly press the two key staves together and slide them in from the top until the croze cut is over the edge of the bottom and then tap them on.
Another approach is to insert the key stave with groove first and then slide the tongued key stave in.

Fixing key stave gap problems involves "shuffling" the staves you first put on to increase or reduce, as necessary, the key stave gap. That is, you will move (shuffle) the staves that you first put on to increase/reduce the key stave gap by peanut butter spreading the excess or deficit evenly between the first "X" number of staves you put on. "X" is typically 8 to 12 staves, but, in unusual situations could involve all the staves on the tub. The goal is to have all the staves staged on the outside red line with the gaps between them all roughly equal. This will insure a nice tight fit between them when you tighten the hoops and round the tub bringing the staves to the inside red line.

Fix #1. Proceed as follows: Install the key staves in the gap against the **last full width** stave you installed. Remove the first two full width staves you installed, which are next to the resulting gap. Reinstall one of the staves you just removed next to the key staves leaving a small gap, approximately 1/16" between it and the key staves. Remove the next stave (3rd stave installed) and move it over and install it leaving a small gap, 1/16" between it and the adjacent stave. Continue your way around the tub repeating this until the gap that is left is a good fit for the final full width stave, leaving just a small gap on either side of it. As stated above, this typically involves no more than "shuffling" about 8 to 12 staves. When done, you can proceed to the next stage of putting on the hoops.

Fix #2. Proceed as follows: Remove the first two full width staves you installed, which are next to the key stave gap. Install the key staves in the gap against the **last full width** stave you installed. Reinstall one of the staves you just removed next to the key staves with a gap of no more than 1/32". Remove the next stave (3rd stave installed) and move it over and install it next to the one just installed with, again, a gap of no more than 1/32" between the two. Work your way around the tub until the gap is a good fit for a full width stave. You may not need to "shuffle" all the staves all the way around the tub to achieve this. When done, you can proceed to the next stage of putting on the hoops.

This is the time to critically examine how things have worked out with standing the staves. Getting it right (the gaps between the staves) at this point is much easier than completing assembly, filling with water and then realizing it was wrong and then having to dry the tub, disassemble it and start over. When we refer to gaps, we are only concerned with the gap at the croze cut level on the inside of the tub. That is the critical part of the tub.

Having all the inter-stave gaps perfectly equal and the key staves fitting perfectly isn't necessary, but you have to make an honest assessment of things at this stage and do a little rework, if necessary. A little backtracking here can save a major rework project later. The gaps between the staves at the inside croze level should be roughly equal and there shouldn't be any gaps of 1/8" or greater between any of the staves. "Shuffle" as necessary any staves to eliminate gaps of 1/8" or greater.

Occasionally, if the tub has been stored for awhile before assembly in an environment that is either wet and humid or very dry (Arizona, New Mexico, etc) the staves may expand or shrink sufficiently that it may be necessary to have us make new key staves and send them to you. This is why we recommend that the tubs be assembled as soon as possible after delivery. This is especially true for dry environments where the wood may shrink. In that instance, if the wood has shrunk so that the key staves are not at all tight, we will probably have to supply new larger key staves.

In the case where the wood has absorbed humidity and expanded, you may be able to trim one or both of the key staves to make them fit if you have a table saw or if you can rig a circular saw with a good guide system that will let you make a clean straight cut. If you don't have tools, but have a lumber yard, Home Depot or Lowe's nearby they will usually make the cut for you. We are happy to supply new key staves in this circumstance, but those options are probably quicker.

INSTALLING THE BANDS/HOOPS

Please note that at this time we are supplying stainless bands instead of hoops due to international shipping problems with our normal round hoops. As this was an unforeseen event, we have not yet had time to change most of the images where necessary to reflect the use of bands rather than hoops. The concepts are the same, but some imagery will show round hoops rather than flat bands. We apologize for any inconvenience and we will be correcting it as soon as possible. Please call us if you have questions.

Hoops

□ It is easiest to assemble the bottom hoop around the base of the tub and slide it up. The other hoops you will slide over the top of the tub. While sliding the hoop, pull the lug and coupler nut away from the wood to prevent marring. If you are doing this alone you can tap in some small nails (no more than 1/4" in) and rest the hoops on the nails, support it on wood blocks to hold it in place. If you have help, the other person can hold it in place on the chalk line opposite the person tightening the lug. Tip: Check the coupler nut and make sure that one of its flat sides will be pressing on the outside of the tub. This will make it slide down the outside of the tub much more easily.

If your chalk lines are unclear or you are re-assembling a tub, the hoop locations measured from the bottom of the stave are:

3' stave: 4" (bottom), 14" (middle), 32" (top)

4' stave: 4" (bottom), 14" (middle #1), 28" (middle #2), 44" (top)

□ Position the lug of the bottom hoop so that it: **1. spans the joint between two staves;** and **2. is as close as possible to the midpoint** of one of the two shortest (half moon shaped) bottom boards.

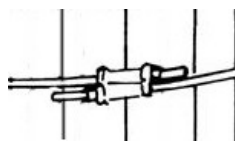

All lugs **must span the joint** between two staves.

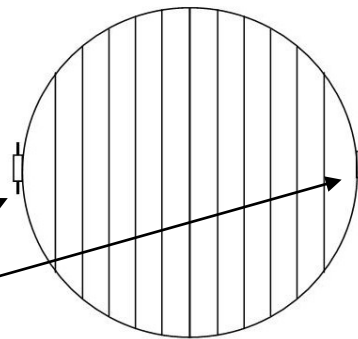

The lug of the bottom hoop should be placed as **close as possible to the center** of **either** of the two half moon bottom boards (as shown) **while spanning the joint** between two staves.

- Remove slack (slack only, you're just positioning the hoops) in the hoop by tightening the nuts with a wrench so that they are tight enough to stay in place. Tighten both nuts equally.
- Repeat process for the remaining hoops. Place the nails (if needed), set the hoop, remove slack).
- The lug placement of the bottom hoop is critical for drawing the two halves of the bottom together. (See picture previous page). The lug of the bottom must both span the joint and be as close as possible to the mid-point of the half moon shaped floor board. Space each subsequent lug three stave joints away from the one below it.

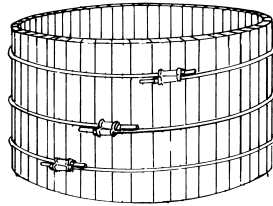

- After all the hoops are positioned, tighten them until they are snug but not tight on the staves. (See the next section for the actual tightening process).

Bands

The bands are much easier to slide on the tub than the hoops, so all bands can be slid down from the top of the top once they are assembled. Also once they are in position they tend to stay there so there is unlikely to be a need to tap in nails to hold them in place. Like the hoops, it is much easier to put them on with two people than with one person. **NOTE: THE EDGES OF THE BANDS CAN BE SHARP. PLEASE WEAR GLOVES TO PROTECT YOUR FINGERS.**

- Position the lugs of the bottom band so they: **1. spans the joint between two staves;** and **2. are as close as possible to the midpoint** of one of the two shortest (half moon shaped) bottom boards. See below illustrations.

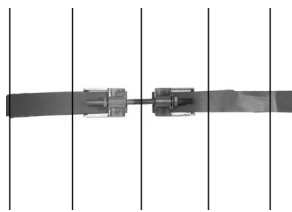

All lug pairs **must span the joint** between two staves.

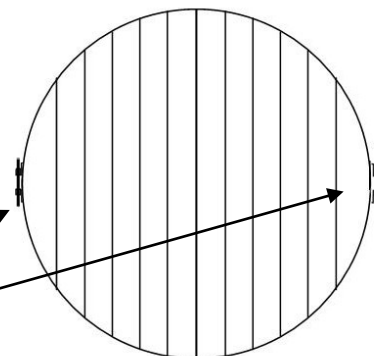

The lugs of the bottom band should be placed as **close as possible to the center of either** of the two half moon bottom boards (as shown) **with each lug on either side of the joint between two staves.**

- Remove slack in the bands so they will stay in place (slack only, you're just positioning the bands) by tightening the nuts with a wrench so that they are tight enough to stay in place. Tighten both nuts equally.
- Repeat process for the remaining bands. Place the nails (if needed), set the band, remove slack).
- The placement of the lugs of the bottom hoop is critical for drawing the two halves of the bottom together. (See picture previous page). The lugs of the bottom band must span the joint and be as close as possible to the mid-point of the half moon shaped floor board. Space each subsequent lug pair three stave joints away from the one below it.

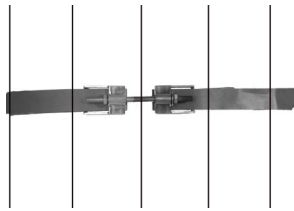

All **lug pairs must span the joint** between two staves.

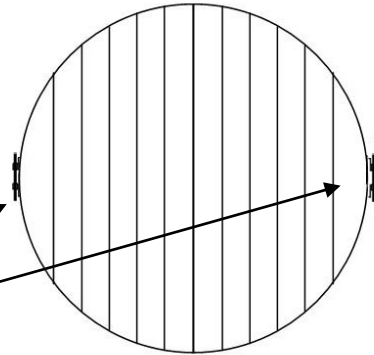

The lugs of the bottom band should be placed as **close as possible to the center of either** of the two half moon bottom boards (as shown) **with each lug on either side of the joint between two staves.**

ROUNDING THE TUB



QR Code for Hoop Installation/Rounding the Tub

This is the most important part of the tub assembly process. At this point the staves should be reasonably snug on the tub bottom and should have a very slight gap (about 1/32” for a 6’ diameter tub, more for smaller tubs and less for larger tubs) between them. Ideally you want the gaps between the stave to be as close to equal as possible.

There should be no large gaps between the staves, nothing larger than 1/8”. If there is a gap of 1/4” or larger between two staves, you should take the hoops off and reposition the staves to eliminate the large gap. All the staves should be covering the outside of the red line. When rounding is completed, the bottom boards and staves should all be snug together. This next series of steps is a repetitive process of “rounding” the tub while tightening the hoops.

“Rounding” is a repetitive process (typically 4 or 5 iterations) of: 1) pounding the **bottom hoop/band** to move the staves inward; 2) tightening the hoops/bands; and 3) keeping the staves aligned so their tongues and grooves stay engaged. Moving the staves inward by pounding the bottom hoop creates slack in all the hoops, which is then taken up by tightening them. This job is easiest when done with two people, one person tightening the hoops while the other is pounding on the **bottom hoop/band** to move the staves in. When done, the center of the staves should be slightly over the inner red line.

We have found that with the bands much less pounding on them is required. As they are more flexible they exert a more uniform force on the staves when they are tightened and tend to draw them in more evenly as compared to the rigid hoops.

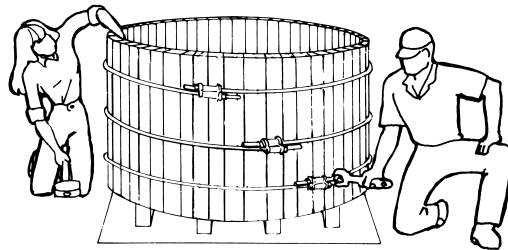

□ 1. Start rounding the tub by hitting the bottom hoop with the mallet to move the staves a little further onto the bottom. **DO NOT HIT THE STAVES DIRECTLY.** Hitting the staves directly can damage them if you are using all your strength. Do not hit the bottom of the staves below the bottom hoop as you may break the bottom of the stave off. Start at the coupler nut of the bottom hoop and work your way around one side to the lug while taking up the slack in each of the lugs by tightening the nuts. Then repeat, starting at the coupler nut and work your way around the other side while again taking up the slack in each of the lugs. **You only need to pound the bottom hoop to help seat the staves on the bottom, do NOT hit the middle or top hoops other than tapping them to align the staves if needed.**

On the first go-round of rounding light blows are all that is needed to move the staves. When you get to the latter iterations of the process considerably more force is needed to move the staves inward. At the end you will need to be hitting the bottom hoop with all you've got to move the staves that last little bit to the inner red line. Again this is less pronounced with the bands.

Caution: Do not try to shortcut the process by tapping the staves all the way on in one pass. To assemble the tub correctly, you must repeat this process 4 or 5 times to insure the staves move in evenly.

DO NOT JUST TIGHTEN THE HOOPS/BANDS TO PULL THE STAVES IN. THIS DOES NOT WORK , ESPECIALLY WITH HOOPS AND CAN STRIP THE THREADS AND YOU WILL BE RESPONSIBLE FOR THEIR REPLACEMENT.

□ 2. You may need to **lightly** tap the staves with the mallet as necessary to keep them aligned. The tongue and groove feature of the staves acts as a self aligning mechanism, but as you move the staves inward, the tongue and groove may become disengaged. You may have to tap the staves both from the inside and the outside and along the length of the staves to get the tongue re-engaged in the groove. When hitting from the inside of the tub, hit opposite the hoop and not in between hoops.

Maintain equal tension on all hoops, as measured by an even amount of exposed thread on hoop ends. **It is critical to not over tighten the upper hoops.** It is easy to over tighten the upper hoops, especially the top one, creating a slightly conically shaped tub as they do not have the resistance provided by the tub bottom. You want the staves to be vertical and the tub to be as close to a true cylinder as possible to maximize its sealing capability. Over tightening the top hoops tilts them inward deforming the geometry of the croze cut against the bottom and is a cause of leaking.

□ 3. You will repeat steps 1 and 2 about 4 or 5 times, drawing the staves a little further onto the tub each time. As the staves are drawn in, you will have to hit the bottom hoop (in step 1) and the staves (step 2) harder and harder to get them to move. This process is a little monotonous and tedious, but will ensure that your tub is as tight as possible. In the final stage of tightening you may need a heavier hammer and block of wood to provide sufficient force to take the last slack out of the hoops. The rubber mallet may be a little light for this. If you can deliver a fairly hefty blow the rubber mallet should suffice

When you aren't able to move the staves anymore by hammering, STOP TIGHTENING. **As a guide,** the amount of exposed thread showing at each end of the hoop should be about as shown in the table below:

| Tub Diameter | Black Iron Hoops | Stainless Hoops | Stainless Bands |
|--------------|------------------|-----------------|-----------------|
| 4' | 3" | N/A | 2 1/8" |
| 5' | 3 1/2" | 3" - 3 1/4" | 2 1/8" |
| 6' | 2 3/4" - 3" | 2 1/2" - 2 3/4" | 2 1/8" |
| 7' | 2 3/4" - 3" | 2 1/4" - 2 1/2" | 2 1/8" |
| 8' | 2" | N/A | 2 1/8" |

It is important to have an approximately even amount of exposed thread on each hoop. However, do not keep tightening to achieve this and strip the threads. If you've reached the point where you can't move the staves anymore, they are over the inner line, and your tub has been creaking and groaning and resonates like a tight drum, you have tightened it as far as you need to.

The final goal is to have the staves tightly compressed against each other with the center of each of stave over the inner red line, ensuring that your tub is nice and tight. As with any hand crafting process, however, there can be variances. Also, wood can expand and contract significantly based on changes in relative humidity which can affect how the tub goes together. Allowing for variances, however, the vast majority of the staves should be on the inner red line with no more than about 5 or 6 staves $1/32''$ - $1/16''$ short of the inner red line. If this is not the case with your tub, you should give us a call before proceeding as there may be a problem.

At this point any gaps between the sides of the staves should be completely closed up and the gap between the two bottom halves shouldn't be more than $1/16''$. If this is not the case, repeat the hammering and tightening of the bottom hoop. If repeated efforts are unsuccessful and there are only a few minimal ($1/32$ - $1/16''$) gaps between staves and **at most** a $3/32''$ gap between bottom boards, you can stop and consider it complete. Sealing might take a little longer, but the tub is capable of swelling and sealing those gaps.

The last step is to apply silicone sealant around the perimeter of the tub bottom, where the staves meet the floor. Using the caulk gun, lay a bead of caulk (about $1/4''$ - $3/8''$ in diameter) at the stave/bottom joint. Then, using the nitrile gloves that were included with the tub, run your forefinger over the sealant with moderate pressure so the sealant is pressed snugly into the joint. The purpose of the silicone is to provide an initial seal for the joint so there is minimal leaking while the wood is swelling and sealing the tub.

FINISHING TOUCHES

Once the tub is assembled, you may want to sand off any sharp corners on the top of the staves.

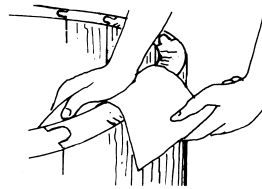

STOVE AND ACCESSORIES

See the installation overview section for a description of how the relative positioning of these items can affect your installation.

□ It is necessary to consider placement of each item you plan to install and any effect it might have on another accessory installed in the hot tub. We recommend reading at least through the stove placement tips on page 21 before beginning any installation processes. Before you install any items inside the tub, determine placement for the following:

- A. Drain (should already be installed)
- B. Benches
- C. Stove
- D. Aluminum Cover,
- E. Jet Fittings

Once placement for the above has been decided, we recommended installing accessories in this order; 1. Drain (if not already installed) 2. Stove and Fence 3. Benches 4. Aluminum cover and/or other cover 5. Jet System/Filter System/Action Pak System

Please refer to the instructions provided for each item for more details.

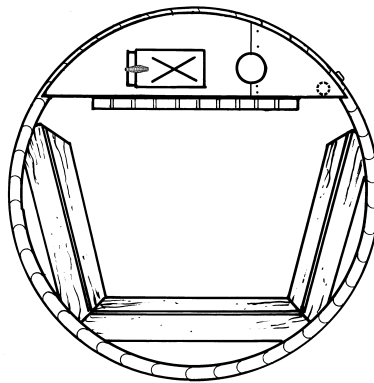

BENCHES



QR Code for Bench Installation Video

If you ordered benches, you received either three (for our wood heated systems) or five (for gas/electric heated Action Pak systems) bench seats, and four 2x6 supports for each seat. The bench supports might look like really short stave pieces. These supports vary in length, allowing you to install your bench seats at staggered heights. If the supports we gave you aren't the exact height you need, just trim down (4) supports per bench to the desired height.

Your benches are installed by screwing two wooden bench supports against the tub wall and two supports under the front ends (forward edge) of the bench. Each bench will require twelve 2 1/2" stainless screws for installation.

- 1. Determine the height you want each bench. Staggering bench heights allows different sized people to enjoy the tub, and also provides seating areas for cooling off. Remember to be mindful of any views you may wish to enjoy as you tub.
- 2. Set bench against tub wall and measure distance from bottom of bench to tub floor. If necessary, trim (4) supports to that desired height. Take two supports, and using two 2 1/2" stainless screws per support carefully screw the supports to tub wall (from the inside of the tub) where your bench touches the staves. Center screws 2" from end on each support.
- 3. Next, screw two supports onto the front of the bench, perpendicular to seat front (see drawing), making sure edge of the support lines up with the front edge of the bench.
- 4. Place bench on top of supports screwed to tub wall. Drive the screws down through the bench into the two supports, completing your installation.

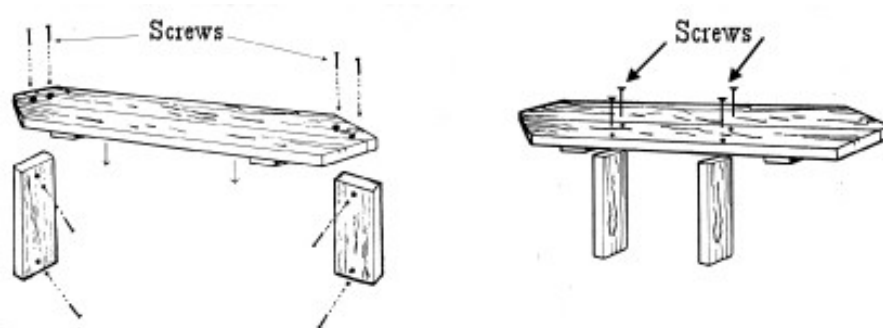

Note - Pre-drilling guide holes for screws prior to putting them in will help prevent splitting in the wood. Also, if your supports are less than 6" in height sink the screws into opposite diagonal corners from each other in order to avoid splitting the support by screwing two screws into the center of a short board.

SNORKEL AND SCUBA STOVE INSTALLATION



QR Code for Stove Installation Video

Before starting the installation of the stove please check the aluminum cover installation section. You will want to make sure that the stove is located in an area that will provide the best possible fit for the aluminum cover before starting to drill holes. **DO NOT INSTALL THE STOVE BEFORE THE TUB IS COMPLETELY ASSEMBLED.** If you drill the mounting holes for the stove before the tub is completely tightened, the holes may no longer be in the proper position and the stove will need to be replaced.

Tool list

- Hammer
 - Pliers
 - Crescent Wrench
 - Drill
 - 5/16" Drill Bit
 - Pencil
-
- 1. Completely read the stove installation instructions before starting.
 - 2. Determine the best stove location and orientation (i.e. do you want to lift the door open with your right or left hand?). If you are installing an aluminum cover, please read the installation instructions before making final determination on your stove location. Also consider stove pipe location, access to woodpile, ease of operation, and view. If you have purchased one of our soft covers the stove **MUST BE** installed with the chimney on a certain side. This side would be the left side if you are standing in the tub facing the stove on or it would be the right side if you are outside the tub and facing the stove.
 - 3. Place stove in tub and climb in with it.
 - 4. Using pliers or a crescent wrench, bend the mounting brackets on the side of the stove to be mounted to the tub so they conform to the curvature of your tub. Do not use a hammer.
 - 5. Hold the stove in place, level, with door opening (top edge of the stove) 1" above the rim of the tub. **THIS IS CRITICAL, OTHERWISE WATER WILL GET INSIDE YOUR STOVE WHEN PEOPLE GET INTO THE TUB.** It is easiest to use supports under the stove to hold it in place, but remove the support before tightening the bolts completely. For a **Snorkel Stove, setting it on a** combination of a fence board and a bench support (or any other 2x6 material) provides just the right amount of height under a Snorkel Stove for its vertical alignment in our 3' tall tubs. Doubling that combination provides just about the right height for a Scuba Stove. **Always check to make sure the door opening is at least 1" above the rim of the tub.**

The Snorkel and Scuba stove both need a minimum of 1" clearance underneath to allow water to draw heat off the metal. The minimum water level for a Snorkel stove is 27" while a Scuba stove requires a 20" minimum water level. This allows for 1" of water under the stove and 3" of water over the stack plate.

- 6. Using a short pencil or chalk, mark the hole locations through the bracket holes, being careful not to move the stove until done. Make sure the brackets are centered as close as possible to the middle of any stave you might drill through. Tip: Cut the end off a sharp pencil creating a stub 3/8" long. Then use a pair of pliers or vice grips to hold it for marking both the tub wall and fence.
- 7. Set the stove aside and drill a 5/16" hole through the tub at each mark, being careful not to splinter the wood. Hold a block of wood on the backside of the stave you are drilling through to help prevent splintering. Use a rasp or file to clean the hole if necessary.
- 8. Open mounting package with carriage bolts, nuts and black rubber washers. Slip the rubber washers onto the carriage bolt until it touches the head of the bolt. Push carriage bolts through holes you just drilled. The bolt head and the O-ring are on the outside of the tub.
- 9. Place stove back into position in the tub running the carriage bolts through the holes in the mounting brackets. Put the nuts on the carriage bolts finger tight. Remove any supports before tightening the bolts then tighten the nuts securely with a crescent wrench.
- 10. Be sure the stove is held securely to the tub wall. The Snorkel and Scuba stoves have over 250 pounds of positive buoyancy when submerged in water. The stoves must be bolted in firmly.

Note: When mounting stove to plastic or fiberglass, steel or other surfaces, use caulk or rubber gasket between stove and wall, and cover the bolt heads with caulk. If your tub wall is thin use 2x4's and build a mounting frame on outside of tub. Bolt through the 2x4's.

If installing a stove in a shallow tub, be aware that when several people get out of the tub the water level can drop significantly, possibly exposing the stack plate. If the fire is still burning, the stove could then easily be damaged.

FENCE ASSEMBLY AND INSTALLATION



QR Code for Fence Assembly Video

SNORKEL STOVE FENCE ASSEMBLY/INSTALLATION

The fence is attached to the Snorkel stove by bolting it to the four mounting brackets facing the center of the tub. The vertical distance between the fence mounting holes is approximately 20” (see drawing). The fence is attached to the stove by four 1 3/4” carriage bolts and wing nuts. The carriage bolts and wing nuts are in your stove mounting pack.

- Mark the three horizontal fence boards for vertical fence board placement according to the diagram. The fence boards are 3 1/2” wide and the gap between them is 1 1/4”. We have provided a 1 1/4” block which you may use as a jig to space your boards appropriately.
- Attach the vertical fence boards to the three horizontal fence boards using the 1 1/4” stainless screws provided. For a clean look, drive the screws from the back of the fence (stove side/side with horizontal boards). For an “industrial look”, drive the screws from the front of the fence (tub side).
- Place the stove on the fence. The mounting bracket holes will be in the center of the second vertical fence board in from each end, see the “X” in the image on the following page. Mark and drill the four 5/16” holes.
- Mount the fence to the stove using the 1 3/4” carriage bolts and wing nuts. (Wing nuts are used for easy removal of the fence for cleaning under the stove.)

The actual inside depths of our tubs are 31” for the three foot tub and 43” for the four foot tub. If your installation is in a shallower tub, adjust the two bottom horizontal boards accordingly.

MOUNTING THE FENCE TO THE STOVE



QR Code for Mounting the Fence to the Stove Video

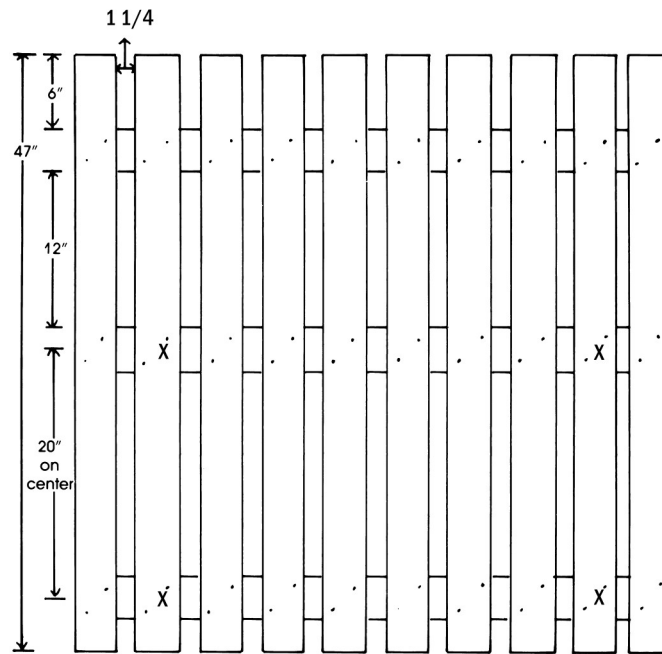

Scuba Stove Fence Assembly/Installation

The fence is attached to the Scuba stove by bolting it to the four mounting brackets facing the center of the tub. The vertical distance between the fence mounting holes is approximately 13" (see drawing). The fence is attached to the stove by four 1 3/4" carriage bolts and wing nuts. The carriage bolts and wing nuts are in your stove mounting pack.

- Mark the two horizontal fence boards for vertical fence board placement according to the diagram. The fence boards are 3 1/2" wide and the gap between them is 1". We have provided a 1" block that you may use as a jig to space boards appropriately.
- Attach the vertical fence boards to the three horizontal fence boards using the 1-1/4" stainless screws provided. For a clean look, drive the screws from the back of the fence (stove side/side with horizontal boards). For an "industrial look", drive the screws from the front of the fence (tub side).

- Place the stove on the fence. The mounting bracket holes will be on the second vertical fence board in from each end, see the “X” in the image below. Mark and drill the four 5/16” holes.
- Mount the fence to the stove using the 1 3/4” carriage bolts and wing nuts. (Wing nuts are used for easy removal of the fence for cleaning under the stove.)

The actual inside depths of our tubs are 2 1/2’ for the three foot tub and 3 1/2’ for the four foot tub. If your installation is in shallower tub, adjust the horizontal boards accordingly.

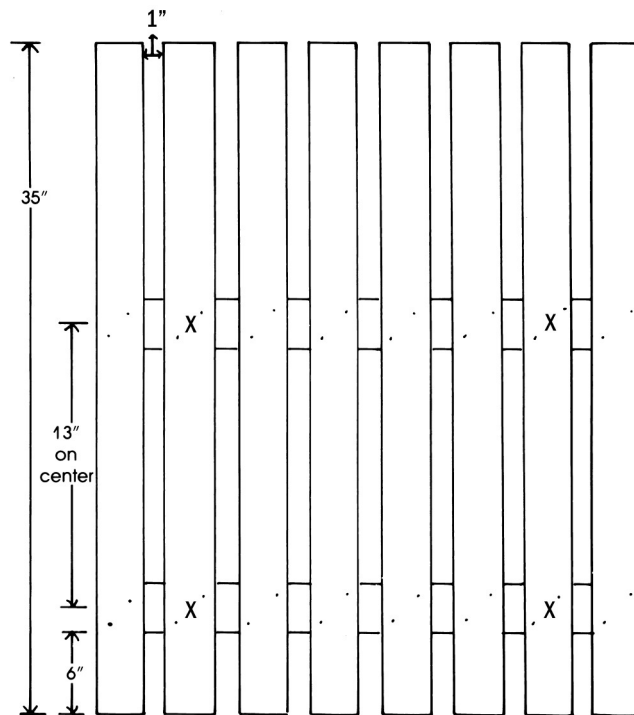

DOOR HANDLE ASSEMBLY



QR Code for Door and/Baffle Assembly

- Bolt the handle to the stove door. The handle should be oriented so the grip is facing the end of the stove door, not the center.

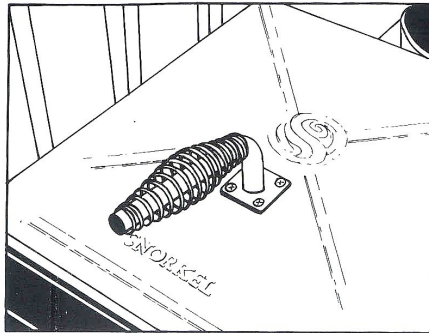

STOVE PIPE INSTALLATION



QR Code for Stove Pipe and Damper Installation

Both the Snorkel and Scuba stove require at least 6 feet of stovepipe to draw properly. Additional pipe may be added to carry smoke, sparks or ash away from roofs, decks, neighbors, etc. Any variety of standard stove pipe will work with our stoves. The Snorkel stove uses 6" diameter pipe and the Scuba uses 5" diameter pipe. Stainless steel pipe, while more expensive, lasts longer and looks more attractive throughout its life. Galvanized pipe is less expensive and will last a little longer than non-coated pipe, about 1 year in rainy climates and longer in dry areas.

□ To assemble galvanized pipe, insert one edge into the slot of the pipe and squeeze it until it snaps into place. If this is difficult, try rolling the pipe on the floor (with a knee placed in the middle) and squeezing at the same time. In either case be careful, the stovepipe has sharp edges. Don't let the pipe fall on your toes. If you have stainless steel pipe with a white plastic coating, simply peel off the coating (it should come off like a large sticker) before assembling the stack.

□ If you are using a damper please see below for installation instructions. You will want to install the damper before placing the chimney stack.

□ Place the chimney pipe over the outside of the stack on the stove body; the crimped end of the pipe should be facing up. This is a tight fit and is intended to provide stability for the stove pipe, but lining up the seam of the stove pipe so that it is slightly offset to one side of the weld seam of the stove stack will make it easier to slide the stove pipe on.

If you have an older stove or a Scuba stove without an exterior stove collar, insert the crimped end of the chimney pipe directly into the stove stack. Once you have the pipe assembled, you may wish to secure the pieces together. You can pop rivet or install sheet metal screws at the joints, using three fasteners per joint. You can secure the pipe to the stove in the same manner. Drill holes 1/4" from the top of the stack.

CHIMNEY CAP

Chimney caps prevent rain from getting inside the stovepipe. Place the chimney cap over the crimped end of the chimney pipe. If you have an older stove or a Scuba stove without an exterior stove collar, insert the chimney cap over the non-crimped end of the chimney pipe.

DAMPER

Dampers give added control over heat output when used in conjunction with the door draft. To increase the efficiency of the stoves, we recommend installing a damper. For outdoor installation, the best location for a damper is six inches above the stove. In an indoor installation it may be advantageous to place the damper further up the stovepipe, allowing heat to radiate into room.

□ 1. First remove the damper handle/pin from the damper. Hold the round part in your hand. Compress the spring on the pin using your palm. Push the wide end until the spring compresses, then turn the pin until you can pull it out of the damper.

□ 2. You will use the handle/pin to make an indentation in the pipe as a drilling guide. First, slide the spring on the handle to one side of the handle. Then, make a mark about 12" up from the non crimped end of the chimney section and 90° away from the welded seam. Position the pointed end of the handle on the mark you just made and use a hammer, to pound the handle so the pin makes an indentation in the pipe. This will help keep the drill from wandering.

□ 3. Put a few drops of all purpose oil on the indentation and drill the hole for the handle

- 4. Next, insert the handle into the hole you just drilled and install the damper plate on the handle. Position the damper so it will swivel freely. Then, use your hammer to pound the handle so it will make an indentation on the other side of the pipe directly opposite the hole you just drilled.
- 5. Remove the damper handle from the damper like you did in #1 above and then use the handle and a hammer to pound the protruding dimple on the pipe that you created in in step 4 back into the pipe. Apply some oil and drill the hole.
- 6. Push the spring on the handle of the pin back in place, insert the pin in the pipe and thread it into the damper and push the pointed end of the pin through the opposite hole and you are done.



PLUMBING INSTALLATION FOR JET AND POWER PAK™ SYSTEMS



QR Code for Plumbing of Suction Fittings

Note: The plumbing procedures are the same for Power Pak™ Gas/Electric heat systems, the Filter Pak and jet systems for wood-fired tubs.

Tool List

- Hack saw □ Drill □ Expanding drill bit or hole saw (capable of 2 1/2" diameter) □ Sand paper
- Dry rag/cloth □ Screw driver □ Teflon tape □ PVC glue & primer rated for flex and rigid PVC.

- 1. Read entire instruction sheet and manufacturer's information to familiarize yourself with project before you start. **Learn, understand and follow your local building codes**, they are designed for your safety. **For reference, Washington state code requires a minimum distance of 6 feet between the pump system and the tub.**

- 2. Check the materials/packing list to verify that you have received all parts and to become familiar with them.

- 3. Mark jet (exhaust) and suction fittings locations on the inside of the tub. **WARNING: FEDERAL LAW AND STATE AND LOCAL REGULATIONS REQUIRE THAT THE SUCTION FITTINGS BE LOCATED AT LEAST THREE (3) FEET APART.** This minimizes the risk of entrapment. If you have a wood-fired system, locate the suction fittings in the area behind the stove and fence where bathers hair or suits are at less risk for entrapment. The best height for the suction fittings is 3" to 9" from the tub floor, and at least 3" from the nearest hoop. The exhaust jets should be below the top hoop and be at least 3" from the nearest hoop. Three staves between each jet is a comfortable distance for the 1 1/2" flexible PVC to bend into place. Center all suction and exhaust fittings in the middle of the staves. The hole for the fittings should not span the joint between two staves.

- 4. Position skid on a firm level surface, at or slightly below the level of the bottom boards.

- 5. Installing the debris trap on the pump: Wrap 3-4 turns (clockwise) of Teflon tape on the threaded intake of the pump. Thread the large black circular fitting from the back of the debris trap onto the pump intake.

- 6. Installing the gate valves: Glue the 1 1/2 x 2 3/4" pieces of PVC into the end of each gate valve. Glue a union fitting onto the opposite end of the 2 3/4" PVC on each gate valve. This allows each of the gate valves to be threaded onto the debris trap and the filter housing (see figure #3, next page).

□ 7. Drill holes for the jet fittings and two suction fittings. A 2 3/8" hole saw is ideal if you have one, but 2 1/2" works fine if a 2 3/8" isn't available. The holes should be in the center of the stave. **THE SUCTION FITTINGS MUST BE LOCATED AT LEAST THREE (3) FEET APART. THIS IS A FEDERAL LAW AND PART OF ALL STATE AND LOCAL REGULATIONS.** Start drilling from the outside of the tub and when the pilot bit for the hole saw penetrates the inside, go to the inside of the tub and finish the hole by drilling to the outside. This will eliminate wood splintering from the hole saw exiting on a straight through cut. Also, you can see where the hole is going to be relative to the hoops and make sure you have enough room for the jet fitting flanges before you finish your cut.

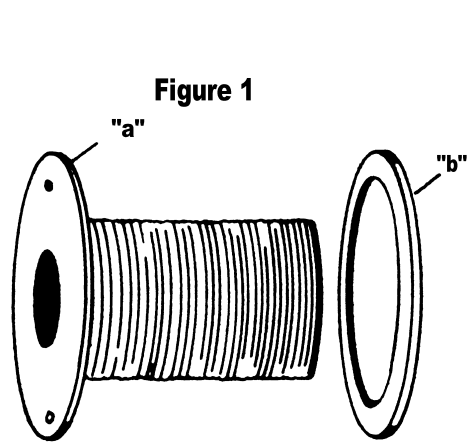

Figure 1

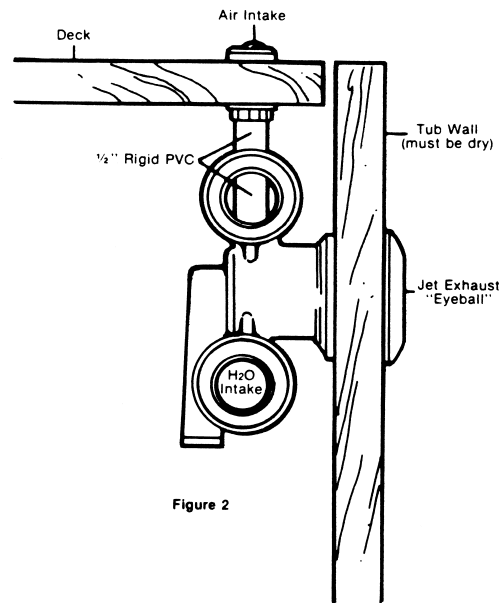

Figure 2

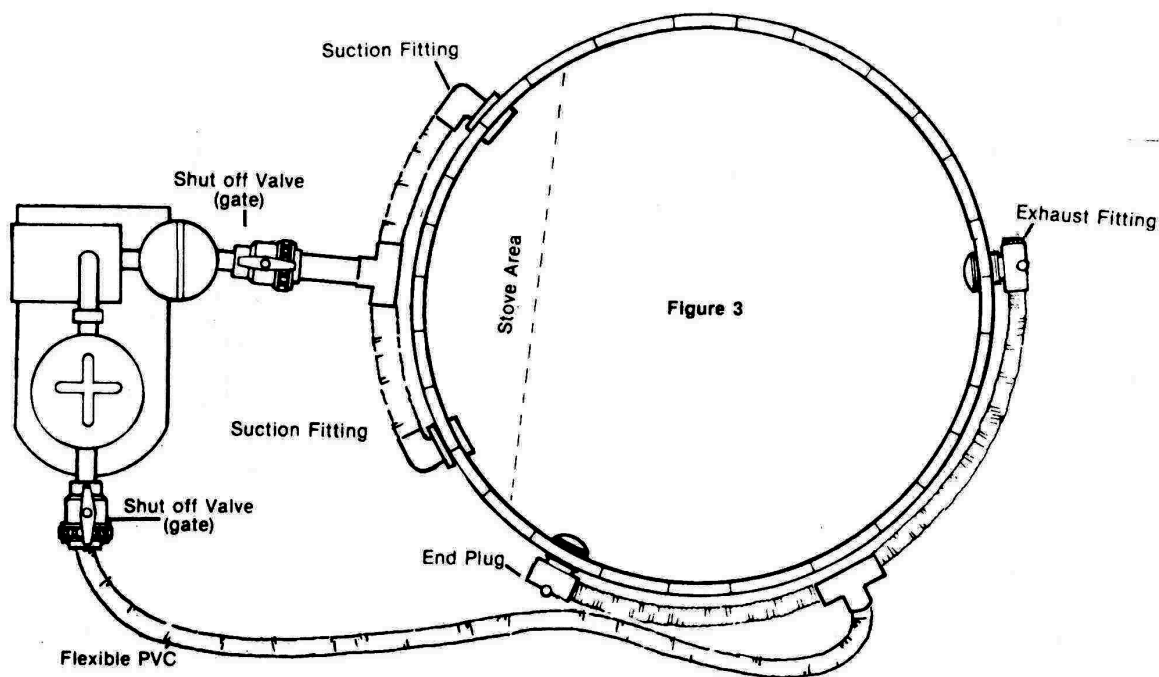

Figure 3

- 8. See Figure #1. Spread silicone sealant freely on surface A, backside of the fitting. Install the rubber gasket and apply silicone to surface B (tub side of the gasket). Slide the fitting into the hole from the inside of the tub. Screw on the outside piece until snug. Make the suction fittings are positioned with outlets facing each other. For jet fittings, stop when the air intake hole is facing up (see Figure #2). Stop tightening all fittings when they are fairly snug, but not too tight as this may cause them to crack as the wood tub swells.
- 9. Cut air intake pipe for the jets (1/2" PVC) to length using a hacksaw. The air intake fittings should be at or above the top of the tub (see Figure #2). Insert the pipe into the jet fittings to check the measurement but do not glue.
- 10. Cut pieces of 1 1/2" flexible PVC to fit between the jet (exhaust) fittings, from the return-side T-fitting to the filter gate valve, from the suction fittings to the T-fitting, and from the T-fitting to the pump/debris trap gate valve (see Figure #3). Because the air intake pipes eliminate the upper set of 1 1/2" holes on the jet fittings, the 1 1/2" flexible PVC is attached to the lower set of holes. The 1 1/2" end plugs are placed over the lower open ends of the jet fittings.
- 11. Completely lay out the flexible PVC for the entire system and dry fit the plumbing pieces prior to gluing to make sure measurements and setup are correct.
- 12. After verifying proper fit of all sections of flex pipe, glue flex pipe into fittings. Dab primer onto outside of flex and into fittings without leaving puddles, and then apply glue in the same manner. Insert the flex into fitting, turn 1/4 turn and hold for 30 seconds before letting go. After gluing all fittings let dry for 24 hours before using! Apply same process with air intake pipes and jet fittings.

WARNING: DO NOT RUN THE PUMP WITHOUT WATER IN THE SYSTEM!

Helpful Tips: You should clean the filter frequently. Close the two gate valves and remove the filter to keep tub from draining and hose it off thoroughly at least once a week. It is a good idea to have two filters, soaking one in filter cleaner while the other is in use. A dirty filter can be a breeding ground for bacteria and algae. It does little good to clean your tub, fill it with clean water, and run that through a dirty filter. Use a hand skimmer to remove surface debris from your hot tub. Change the water as often as you can afford to. Chemical build-up is hard on plumbing, wood, and aluminum, especially when combined with hard water.

WINTER USE OF JET SYSTEM

When the air temperature is below freezing, leave the pump running on low to help prevent damage to the system. In cold climates, keep pump/filter in a heated or insulated space. If you have trouble with freezing, you may drain the system and still use the tub by installing screw plugs in place of eyeball jets and suction screen fittings. Be sure to drain the pump and filter completely to prevent damage.

FILTER PAK & SIMPLE SOAKER (no jets)



QR Code for Plumbing of Suction Fittings

Tool List

□ Hack saw □ Drill □ Expanding drill bit or hole saw (capable of 2 1/2" diameter) □ Keyhole saw
□ Sand paper □ Dry rag/cloth □ Large nail □ Pipe wrench □ Screw driver □ Teflon tape □ PVC
glue & primer

□ 1. Read entire instruction sheet and manufacturer's information to familiarize yourself with project before you start. **Learn, understand and follow your local building codes**, they are designed for your safety. **For reference, Washington state code requires a minimum distance of 6 feet between the pump system and the tub.**

□ 2. Check the materials/packing list to verify that you have received all parts and to become familiar with them.

□ 3. Mark jet (exhaust) and suction fittings locations on the inside of the tub. **WARNING: FEDERAL LAW AND STATE AND LOCAL REGULATIONS REQUIRE THAT THE SUCTION FITTINGS BE LOCATED AT LEAST THREE (3) FEET APART.** This minimizes the risk of entrapment. If you have a wood-fired system, locate the suction fittings in the area behind the stove and fence where bathers hair or suits are at less risk for entrapment. The best height for the suction fittings is 3" to 9" from the bottom of the tub, and at least 3" from the nearest hoop. The exhaust jets should be below the top hoop and be at least 3" from the nearest hoop. Three staves between each jet is a comfortable distance for the 1 1/2" flexible PVC to bend into place. Center all suction and exhaust fittings in the middle of the staves. The hole for the fittings should not span the joint between two staves.

□ 4. Position skid on a firm level surface, preferably at or slightly below the level of the tub bottom.

□ 6. Installing the gate valves: Glue the 1 1/2" x 2 3/4" pieces of PVC into the end of each gate valve. Glue a union fitting onto the opposite end of the 2 3/4" PVC on each gate valve. This allows each of the gate valves to be threaded onto pump and the filter housing (see Figure #3).

□ 7. Drill 2 1/2" holes for the return and the two suction fittings. The holes should be in the center of the stave and **the suction fittings MUST be at least 3' apart**. Start drilling from the outside of the tub and when the pilot bit for the hole saw penetrates the inside, go to the inside of the tub and finish the hole by drilling to the outside. This will eliminate wood splintering from the hole saw exiting on a straight through cut. Also, when starting from the outside of the tub, you can see where the hole is going to be relative to the hoops and ensure you have enough room for the fitting flanges before you start your cut.

- 8. Spread silicone sealant freely on surface A (see Figure #1 page 28), the backside of the fitting. Install the rubber gasket and apply silicone to surface B (tub side of the gasket). Slide the fitting into the hole from the inside of the tub. Screw on the outside piece until snug. Make sure suction fittings are positioned with outlets facing each other. Stop tightening all fittings when they are fairly snug, but don't over tighten as this may cause them to crack as the wood tub swells.

- 9. Completely lay out the flexible PVC for the entire system and dry fit the plumbing pieces prior to gluing to make sure measurements and setup are correct.

- 10. After verifying proper fit of all sections of flex pipe, glue flex pipe into fittings. Dab primer onto outside of flex and into fittings without leaving puddles, and then apply glue in the same manner. Insert the flex into fitting, turn 1/4 turn and hold for 30 seconds before letting go. After gluing all fittings let dry for 24 hours before using!

MAKE SURE YOU HAVE FOLLOWED ALL BUILDING CODES FOR ELECTRICAL CONNECTIONS BEFORE YOU PLUG IN FILTER UNIT.

Helpful Tips: Follow manufacturer's instructions for pump unit startup. You should clean the filter frequently. Close the wall fittings off by plugging them with the enclosed plugs. They screw into the wall fitting from the inside of the tub. There is a small drain plug located near the base of the filter canister. Hose the filter cartridge off thoroughly once per week. It's also a good idea to soak the filter in filter cleaner as needed to keep water flowing freely through your system. The filter is the prime breeding ground for bacteria and algae. It does little good to clean your tub and then run the clean new water through a dirty filter.

WINTER USE OF FILTER SYSTEM

When air temperature is below freezing, leave pump running on low to prevent damage to system. In cold climates, keep pump/filter in heated or insulated space. If you have trouble with freezing, you may drain filter unit and still use tub by installing screw in plugs in wall fittings as described in the above section. Be sure to drain pump and filter completely.

ELECTRIC AND GAS HEATED POWER PAK™ SYSTEMS

The installation of the plumbing components: suction fitting, jets, etc is the same as for a wood-fired jet system. Follow the jet system planning and installation instructions on page 34.

Complete Power Pak™ installation instructions along with manufacturers instructions are included in a separate manual.

ALL GAS AND ELECTRICAL CONNECTIONS AND HOOKUPS **MUST** BE MADE QUALIFIED ELCTRICIANS AND GAS COMPANY TECHNICIANS AS APPLICABLE.

FILLING AND SEALING THE TUB

Your tub will seal itself and achieve a watertight seal through the natural swelling of the wood that occurs as water is absorbed into the wood.

Begin to fill your tub with water using a standard garden hose. If your water supply is limited, see tip#4 in the following section on leaks.

Once the tub has begun to hold water, you can expect some dripping and leaking. If you have done a superior job it may hardly leak at all. If your tub is not as tight as some it may leak more. Don't get nervous if you see small streams of water. As long as you have closed your gaps to less than the thickness of a matchbook cover and there aren't more than a half dozen or so such gaps between the staves, the tub will be able to swell and seal itself. If your tub is holding water above the minimum water level of the stove, and you plan on keeping a careful eye on the water level, you can start a small fire and heat your tub up a bit. The warm water helps the wood swell. Don't let the water drop below the minimum water level on the stove.

The swelling and sealing process may take three days to a week to run its course. Cold winter weather can cause the swelling process to take longer. Occasionally, a tub may even drain completely after the initial filling, but the wood is absorbing water and swelling so keep adding water.

TIPS IF YOU EXPERIENCE LEAKS

There are a number of steps you can take to reduce the leaking and/or speed up the swelling of the wood.

1. First, if you have a big leak, say pencil sized stream or larger, or if you are concerned, call us at 1-800-962-6208. We are here to help. With a leak that large you will probably need to do some disassembly/reassembly.
2. If there is a leak between staves or the bottom halves coming from an obvious gap and the gap is less than 1/8" , tear or cut a strip of a brown paper shopping bag, get it wet and tape it over the opening. This can reduce water loss while the wood swells.

3. One of the simplest general purpose solutions for stopping leaks in a new tub is an old tank maker's trick, using sawdust. Make a paste from fine sawdust and water and then press the paste into the areas in the tub where there is leaking. Then fill the tub slowly. The sawdust will be drawn towards the void where the leak is and block it or slow it down. This is a temporary measure that slows leaking enough to retain water in the tub so the wood can become saturated and swell.
4. If you are in a location where water is a scarce resource and you are concerned about excess water use, there are two other approaches that use less water than just running a hose until any leaks have stopped. The first is to get a couple of buckets of hot tap water and put those in the tub. The hot water speeds up the swelling process significantly. The other approach is to use a lawn sprinkler. Put it in the tub and turn it on low. The water will keep the stave and floorboards wet so they will swell without wasting a lot of water.

Again, if you are having problems and aren't sure what to do, call us.

TANNIN LEACHING

At first, tannins from the wood will leach into the water turning it reddish brown. This leaching process may last anywhere from 2 - 3 months depending on the amount of tannin contained in the wood. The tannins are not harmful and in fact are indicative of the amount of natural preservative in the wood, but they can discolor bathing suits.

The discoloration of the water can be controlled with chlorine and related standard spa chemicals. Because the tannins leach out quickly at first, you will find that you have to replenish the chlorine fairly often in order to keep the water clear, but this should decrease noticeably after a few weeks. As always when adding chlorine to a tub, dissolve it in water in a bucket first. **NEVER ADD CHLORINE TO A TUB BY SIMPLY THROWING CHLORINE GRANULES DIRECTLY INTO IT.**

SANITATION

PLEASE READ THE ENCLOSED BOOKLET PUBLISHED BY THE SEATTLE KING COUNTY PUBLIC HEALTH DEPARTMENT THOROUGHLY. MAKE THIS INFORMATION AVAILABLE TO ALL BATHERS WHO WILL BE USING YOUR HOT TUB. THIS IS SAFETY AND HEALTH INFORMATION.

Hot tub water that is improperly maintained can commonly cause an irritating poison ivy like rash that is painful and uncomfortable. The rash is caused by pseudomonas, a common bacterium which is present in most water supplies and on people's skin. It reproduces quickly, especially at normal tubbing temperatures. This is even more prevalent when a large number of people are using the tub. Much less common, but far more dangerous is the Legionella bacterium which causes the potentially fatal Legionnaires disease. To avoid these problems, it is essential that you maintain your hot tub water properly.

A spa or tub requires more vigilant water maintenance than a pool. Generally a hot tub has only about 2-3% as much water as a pool, and is kept 20-30 degrees warmer. Moreover, 5 or 6 people in a hot tub can be the equivalent to 150 to 160 people in a swimming pool. The King County booklet we have provided is an excellent reference for water cleanliness.

JAPANESE STYLE BATHING

Traditionally in Japan, many people, regardless of wealth, enjoy a daily hot tub. Everyone scrubs themselves clean before entering the hot tub to prevent contaminating the water. In addition the water is changed regularly. The baths are large enough to be comfortable, but not so large as to be wasteful. Many are heated with wood or coal.

Our wood-fired hot tubs may be used Japanese style - i.e., simply draining, cleaning and refilling. The frequency with which you change your water will depend on a number of variables. The variables include the number of bathers, how clean they are when they enter the tub, and the size of the tub. This method is a practical alternative with our quick heating stoves (but not with systems that require plumbing), and is used by many people who don't want to use chemicals. In considering your sanitation plan, please bear in mind that a hot tub is really just a large bath tub and if in doubt always use a sanitizer such as chlorine.

If you are going to use your tub Japanese style, there are four important elements.

1. The bather is clean upon entering the tub. (Scrub off with soap and water right before entering)
2. Water is changed frequently (this can be once a day with a high bather load like a family party over a special weekend). You should strongly consider using chlorine when there are going to be a large number of people using the tub regardless of your preferences on chemicals. Your guests' safety should come first.
3. If your water looks dirty, or is in any way questionable, change it.

4. Clean your tub with a bleach and water solution (follow guidelines on bleach container, typically about a half cup per gallon) and scrub with a stiff brush, then rinse with clean water before refilling.

IMPORTANT: If this is not a practical solution for your installation you should follow the water maintenance program outlined in the enclosed booklet published by the Seattle King County Public Health Department.

MAINTENANCE

Wood hot tubs require little maintenance. It is best to leave them full of water. This reduces expansion and contraction of the wood, which can shorten its life. **However, during the winter you do not want your tub to freeze solid.** (See our section on freezing.) If your tub shows signs of wear after a number of years, the easiest thing to do is to sand the interior surface with standard sandpaper.

FREEZING WEATHER

How you deal with freezing temperatures will differ depending on your usage pattern and whether you have a wood-fired tub or one heated with gas or electricity.

WOOD-FIRED TUBS

While our wood-fired tubs don't have any plumbing to freeze and break, letting your tub freeze to a solid block of ice may cause severe damage to the tub. If you will be using your tub every week or ten days you can probably get by with doing nothing if the temperatures are above zero. If you won't be using your tub during extended periods during freezing temperatures, there are a number of approaches you can take.

1. Some owners who have electricity near the tub like to use stock tank heaters to keep the water from freezing.
2. If electricity is unavailable and water to refill your tub isn't a problem, drain all but about six inches of water from the tub. This will keep the bottom sealed and no damage will occur.
3. Some owners with tubs at cabins where there is no water available during winter to refill during their visits leave their tubs full, but secure a large, partially inflated inner tube to the bottom of the tub. A similar and easier approach is to anchor several air-filled plastic milk jugs at various levels of the tub. Either procedure allows the inner tube or milk jugs to take the stress of the expanding ice so that the tub is not damaged. (The inner tube needs to be completely submerged near or at the bottom).

When heating a frozen or partially frozen tub with a Snorkel Stove® heater, make sure the stove is covered by sufficient ice/water. Then build a small fire and let the stove heat slowly. A fast burning fire quickly melts the ice around the stove and then boils the water away exposing the stove to air. **Without water surrounding the stove, it can melt.** If necessary, add water to the tub on top of the frozen surface while melting the ice.

FREEZING (cont'd)

GAS AND ELECTRIC HEATED TUBS

With gas and electrically heated tubs the simple option (not available to wood-fired tub owners) is to simply set the thermostat and forget it. That said, power outages in cold weather can create real havoc. If the temperatures are quite cold, 5-10 Fahrenheit degrees or less, the water in the heater and plumbing can freeze fairly quickly and break the pipes and interior components in the heater. Once that happens the tub is the subject to freezing.

If you are going to be around the tub (at home for instance) and are able to react to things like power outages, you can certainly just leave the tub running as you normally would. If you are going to be away for an extend period, and don't want to take chances, you may want to drain the system components: heater, filter canister, flex PVC, gas heater and tub (leaving the water below the suction fitting in the tub to keep the bottom seasoned).

EXTERIOR FINISHING

It is not necessary to coat the tub with a protective finish. Left alone the tub will weather and turn light gray. We recommend that you do not use wood sealer or paints on the tub, because the wood benefits from exposure to the air. The water will seal the interior surface; therefore it is important to leave the exterior surface unsealed so it can breathe.

If you want your tub to have a finished look, you can apply boiled linseed oil to the exterior. It is absorbed into the wood without making a permanent seal. When applying linseed, coat the exterior (only) with a brush or roller. Before disposing of the application tools let them dry out in a non-confined, well ventilated area. They are prone to spontaneously combust if placed in a confined area.

MOVING YOUR TUB

When possible, it is easiest to move your tub assembled.

1. Drain your tub and let it dry for a bit. It will be lighter than if the wood is saturated.
2. Remove stovepipe and plumbing fittings from the tub.
3. With a few helpers, tip tub onto its side.
4. Roll on the steel hoops. If necessary use lumber to build a ramp into your moving vehicle. Block into place with the chime joists, placing them on both ends of the tub. Secure with tie downs.
5. When resituating make sure the chime joists are perpendicular to the floor boards. You may have to re-tension at least the bottom hoop by pounding on it and tightening the nuts.

DISASSEMBLING AND REASSEMBLING THE TUB

To disassemble your tub:

- 1. Allow the wood to dry and contract. This will help minimize disassembly damage.

- 2. Carefully tap the staves off from the inside. Tap the staves gently at the bottom of the tub. Be extra careful not to pry the staves off and split them
- 3. If you are going to store the wood for an extended period, stack the staves with spacers in between them so the air can circulate between them and dry them evenly. Store them in a protected area. They will still contain moisture and can split or crack if not allowed to dry evenly, i.e. if stacked tightly together. Allowing the wood to dry evenly prevents warping and splitting. Follow tub assembly instructions for reassembly. The staves may shrink over time to the point where you may need to purchase one or two new ones to get complete coverage around the tub.

COVERS

FOAM COVER

Our closed cell foam cover material provides 1/4" of insulation and when trimmed carefully also greatly reduces evaporative heat loss. To trim the foam cover, it is easiest to make a template to fit your tub (you can use the cardboard the tub came in) and then put this pattern over the foam cover and cut it to size.

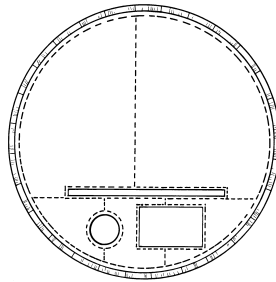

WOOD COVER



QR Code for Wood Cover Assembly Video

A wood cover helps to keep out leaves and other debris in addition to providing dead air space to prevent heat loss. If you purchased a wood cover you will need to attach the cover blocks (4 screws each) to the underside of the cover, as shown on following page. They should be spaced 2 1/4" - 2 1/2" in from the edge. They position the cover and help prevent the sections from falling the tub when removed. If you want your cover to function as a safety cover, use a strap and locks on each end to secure the cover.

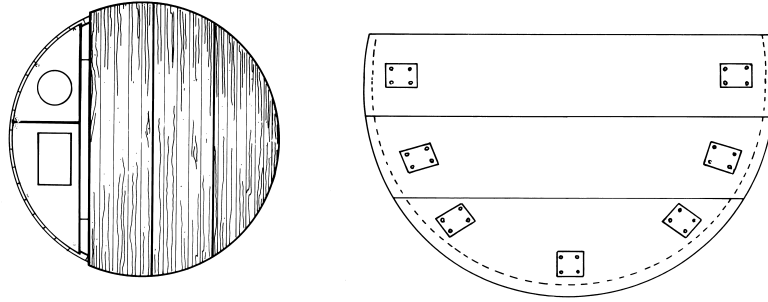

ALUMINUM COVER



QR Code for Aluminum Cover Assembly

Our aluminum covers are machine cut to a true circle and your tub most likely is not a perfect circle so the fit around the rim of the tub may be just slightly off. The cutouts for the stack and stove door have some extra clearance (about 1/4") so there shouldn't be any problem with fit. It just may overhang or be a little short of the edge of the tub.

□ Refer to drawing for part identification. Attach the angle bracket to the fence, about midway between the cutout for the door and the cutout for the stack, with the 3/4" sheet metal screw. The angle bracket supports Part A. Fasten the two aluminum support strips to Part A. Part B rests on the strip.

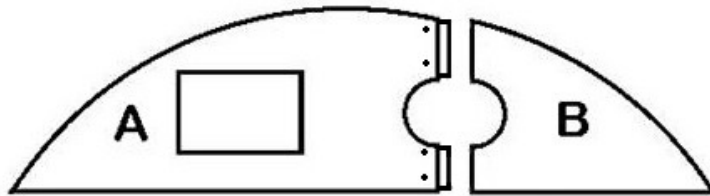

SNORKEL® AND SCUBA® STOVE OPERATING INSTRUCTIONS

ALWAYS MAKE SURE TO MAINTAIN THE PROPER WATER LEVEL AROUND THE STOVE.

The stove is made of aluminum and will melt at the hot temperatures produced by wood fires if not submerged sufficiently in water. The label on the end of the stove indicates the minimum water level. It is essential that the stack plate, (the horizontal plate from which the chimney flue emerges) be covered with at least 1" of water. If the stack plate is exposed to air when a fire is burning in the stove, it can melt in a matter of minutes. Most problems occur when owners let friends use their hot tub without adequate instructions. Be sure to inform anyone using the tub that it must be filled

with water before starting a fire.

It is very easy to start a fire in the Snorkel® and Scuba® Stoves

1. Place several pieces of wadded newspaper or cardboard on the bottom of the stove.
2. Over this, lay generous amount of kindling and small logs in a criss-cross pattern.
3. Check to make sure the damper is open.
4. Light the paper and set the door to the edge of the intake baffle (the steel divider). Air will draw in through the Snorkel air intake quickly finding the fire, and then draft up the chimney. To produce a clean burn, always start your fire with clean, dry kindling. If you get excessive smoke, reduce the amount of wood you are starting your fire with.
5. Once the fire has taken hold add more wood to the stove. Start by adding smaller pieces slowly. Give the fuel a chance to catch fire; this helps eliminate smothering your fire and excessive smoking. You eventually want to have your stove 1/2 filled with burning wood. Refill frequently (visiting the stove box every 20 minutes or so) to produce the optimum heating rates. If your fire dies out, your stove is not heating at its full capacity. Keep your fire burning hot until your tub is about 10 degrees from desired tubbing temperature, then begin to let the fire burn down. The hotter and faster the fire burns the quicker the tub will heat up. Most people tub at 102-104 degrees.
6. Occasionally stir the water to prevent stratification (i.e. hot water on top, cold on the bottom), check the temperature and decide whether you need to add more wood to the fire.
7. Check the water temperature before entering the tub. Make sure it is within the recommended levels outlined in the King County Spa and Hot Tub Manual. Most people tub between 102-104. .

For maximum draft and fastest rate of burn, position the door fully open. That is, with the leading edge of the door lined up with the baffle.

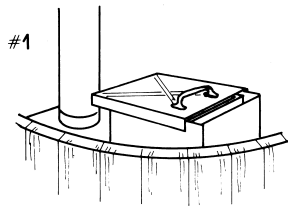

You can put the fire out by sliding the door completely across the opening. This cuts off the air intake to the fire.

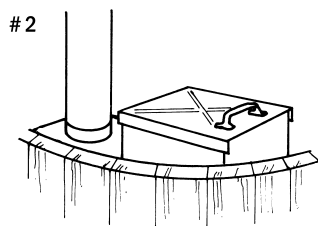

Always close door when stove is not in use

Adjusting the damper will help increase the efficiency. When the stack is producing clear exhaust, your stove is burning at its maximum efficiency.

CAUTION: Always use care when operating a wood stove. Keep hands, face, head and clothing away from the door and the chimney sections. Always open damper prior to opening the door for fueling and starting stove.

TEMPERATURE CONTROL AND EFFICIENCY

With our wood burning stoves it is possible to heat the water in excess of the normal maximum hot tub temperature, 104°. If you are heating beyond this temperature, please use extreme caution to ensure that no one accidentally enters the tub. Always check the temperature before entering.

Heating rates vary depending on the species of wood used for fuel, its dryness, how frequently you refuel your stove, and the size of your fuel. These factors all determine the BTU output rate.

For maximum heating speed, cut your wood small, fill the stove as full as possible, set the air intake to allow maximum draw (diagram #1), and set the damper (if any) at 45 degrees. For longer burns and more efficiency, use less airflow. Restrict exit first with the damper, then the intake.

Without agitation, water will stratify into layers, with the hottest water on the top. Heat loss will occur more slowly if you mix the water up occasionally. A simple approach is to use a board or canoe paddle to stir the water, make sure to pull the cold water to the surface.

An excellent alternative to stirring the water with a board or paddle is to circulate the water with one of our stand-alone filter systems. They provide water movement and filtration and increase the efficiency of the heat transfer from the stove. A small circulating pump can also be used.

If you overheat the water, it is easy to cool the tub back down. Simply add cold water and mix it with the existing water until the desired temperature is reached. After using the stove a few times, you will be able to gauge fairly accurately the heating time required.

If you are leaving for the day and want a hot tub on your return, fill up the stove with wood and use the damper to slow the rate of burn. It should be hot when you return. This is not recommended in high fire season. It is always best to have someone attending a wood-burning stove. Always agitate the water and check the temperature before entering the hot tub.

STOVE MAINTENANCE

ASH REMOVAL

Your stove will heat more efficiently if the ashes are cleaned out frequently. The bottom of your stove is an important heat transfer surface and old ashes can act as an insulating barrier. Use our ash scoop or a shop vac to remove ashes. Ensure the fire is out before vacuuming or otherwise

disposing of the ashes.

If you live in a wet climate it is important to remove the ashes after every fire and to prevent water from getting in the stove. The mixture of water and ash forms lye, which can quickly eat through the aluminum stove.

The stove flue is designed to have the chimney sections mounted the opposite of normal stove-pipe. That is, the crimped section is to point up rather than down. This provides a shingling effect making the water run down the outside of the stovepipe instead of directing to the inside of the pipe and into the stove. This help keeps the water out of the stove, but a chimney cap should also be used.

The stove door provides good cover for the feed opening, but if water is still getting in, put a plastic sheet over the stove door opening (the fire must be out) and then put the door on to hold the plastic in place. Always close the stove door and provide some cover for the chimney pipe (cap or bucket, etc) when not in use to keep the rain out. If you will be gone for an extended period, remove the stack and put a bucket or something similar over the flue pipe of the stove.

Creosote can build up inside the stove and reduce efficiency. This usually occurs when the stove is not fired hot and fast. This may be eliminated by a couple of hot fires or a little scraping with the ash scoop or shovel.

SMOKE

Most stoves will smoke a bit when first ignited. A slow burning fire generally produces more smoke, indicating less efficiency than a fast burning fire. If you are concerned about neighbors, it is best to burn a hot and fast fire. To achieve this, use smaller pieces of wood, load the wood with lots of space for air circulation, and only fill the fire box up half way. Pull the stove door straight back so that it is touching the chimney pipe and set the damper at a 45 degree angle. Do not burn scrap wood covered with grease, glue or paint.

CAUTIONS

NEVER FIRE STOVE UNLESS WATER LEVEL IS ABOVE STACK PLATE

If the water level drops below the stack plate (the horizontal surface to which the stack (flue) is welded) you must immediately put out the fire to protect the stove from excessive heat. You can put the fire out by closing the stove door completely or dousing with water. Keep the stove cool by running water over it. Operating the stove with an insufficient water level could cause warping of the stack plate, and thereby void your warranty. As long as the fire is put out immediately, your stack plate should be safe.

DON'T DRAIN YOUR TUB WITH A FIRE IN THE STOVE

If you are in a hurry, throw a few buckets of water in the stove and put out the fire.

NEVER OPERATE YOUR STOVE WITHOUT A PROTECTIVE FENCE

Although the body of the stove remains cool, the door and stovepipe get hot and can cause a bad burn if touched. In addition, the fence mounting brackets are sharp and can be dangerous without the fence to shield you from them.

USE CAUTION: THE STOVE DOOR AND STOVE PIPE GET VERY HOT

OPEN DAMPER FIRST BEFORE FIRING AND RELOADING STOVE

Opening the damper first will prevent smoke and possibly flames from exiting through the door opening. Stove door may get hotter when using a damper.

SAFETY CONCERNS

Hot tubs are not toys, nor are they places for small children. Never let your tub be used by unsupervised children. Drowning is a very real risk. Hot tubs are designed for sitting and relaxing in. Never use a hot tub for playing in or diving in. Please review the Safety and Accident Prevention information starting on page 4 of the King County Health Manual with your family. Put this information into practice.

Children should use the tub at lower temperatures. Consult your personal physician regarding hot tubbing and children, pregnant women, or if you have specific questions relating to your health and safety. Hot tubbing can accelerate your heartbeat, lower your sperm count, and may overheat pregnant women. Don't take long hot baths if you are concerned about these items. Consult your physician if you are concerned. Drinking, drugs and hot tubs do not mix and can be lethal.

The enclosed King County Department of Health booklet also contains a wealth of information pertaining to using and maintaining hot tubs and sanitation.

SHELF MOUNTING INSTRUCTIONS

1. Attach shelf braces to shelf by inserting carriage bolt through hole. Screw on washer and nut. Tighten with wrench.
2. Attach angle brackets to shelf and braces with 2 1/2" lag bolts. (Mark and pre-tap holes 1/2" deep).
3. Rest shelf on top hoop of tub. Make sure the notch in shelf fits over the hoop. The center of the shelf should contact the tub.
4. Avoid positioning lag bolts on a stave joint.
5. Mark and pre-tap 1/4" diameter holes 1/2" deep into tub wall. Mount shelf to tub with 1 1/4" lag bolts.

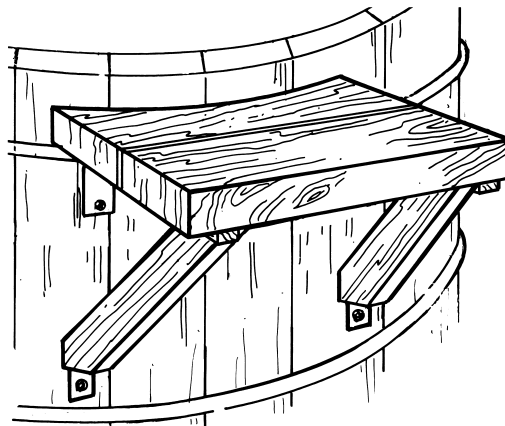

FENCE SHELF INSTRUCTIONS

1. Place the fence shelf on the fence in front of the stove, so that the fence is situated between the shelf cleats/supports on the bottom of the fence shelf.
2. No assembly is required and the fence shelf can be moved as desired.

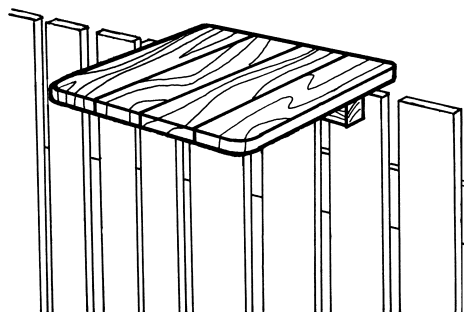

BOX STEP ASSEMBLY (15" & 30")

1. Use the drawing and predrilled holes as a guide for screw locations.
2. Screw both side sections to the front.
3. Screw the back section to the sides.
4. Screw the top to the completed base.
5. Attach angle bracket to the under side of step. (Pre drilling will help prevent splitting).
6. Attach steps to the tub using four 1" screws. (Pre drilling will help prevent splitting).

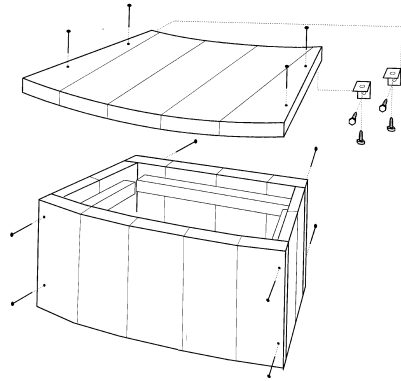

STAIR KIT ASSEMBLY

1. See drawing for detail.
2. Attach treads to jacks (pre-drill holes for lag bolts).
3. Attach rear rail support to left side of steps.
4. Attach step support to right side of steps.
5. Attach front rail support and railing.
6. Tap diagonal support before nailing.
7. Screw diagonal support brace across rear of stairs.

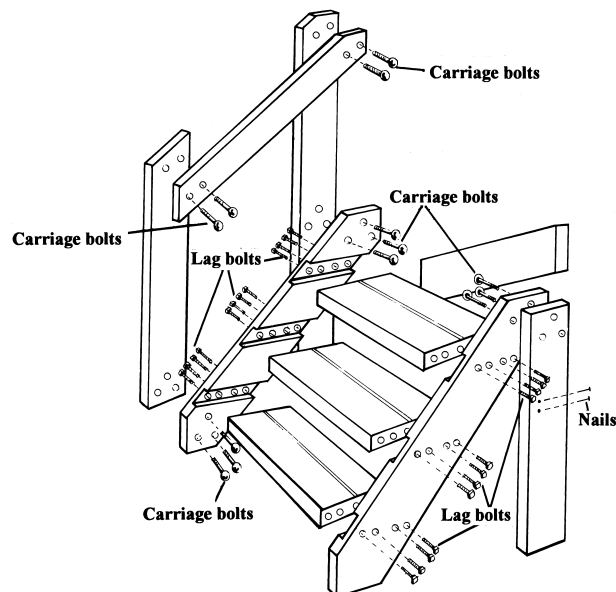

WARRANTY

THE FOREGOING WARRANTY IS EXCLUSIVE AND IN LIEU OF ALL OTHER EXPRESSED AND IMPLIED WARRANTIES WHATSOEVER, INCLUDING BUT NOT LIMITED TO IMPLIED WARRANTIES OF MERCHANTABILITY AND FITNESS FOR PARTICULAR PURPOSE. UNDER NO CIRCUMSTANCES SHALL SNORKEL STOVE COMPANY, ITS OFFICERS, DIRECTORS, EMPLOYEES, CONTRACTORS OR AGENTS BE SUBJECT TO ANY CONSEQUENTIAL, INCIDENTAL, INDIRECT, OR CONTINGENT DAMAGES WHATSOEVER WITH RESPECT TO CLAIMS MADE HEREUNDER OR BY ANY PURCHASER OR USER OF PRODUCTS.

The Purchaser shall indemnify and hold harmless Snorkel Stove Company, its officers, directors, employees, contractors and agents, from and against any and all liabilities, damages, losses, claims, lawsuits, including costs and expenses in connection therewith, for death or injury to any persons or loss of property whatsoever, caused in any manner by Purchaser's possession, use or operation of the Products.

- 1.) Snorkel Stove Company warrants that its wood tubs, seats, steps and other wooden accessories shall be free from defects in material and workmanship under normal conditions of use and service for a period of five (5) years.
- 2.) The Snorkel Stove Company fully warrants stove models Snorkel and Scuba shall be free from defects in material and workmanship under normal conditions of use and service for one (1) year. The Snorkel Stove Company will repair, replace or provide replacement parts for said defective stove units: at its expense including freight.

The warranty period begins on the date the item is shipped from The Snorkel Stove Company or one of its authorized dealers.

Warranty is void if the product has been misused or damaged and/or if evidence is present that the product was altered, modified or serviced by unauthorized service people. Proper use is outlined in the owner's manual entitled: "**Assembly, Installation and Owners Manual for Snorkel Hot Tubs, Stoves and Accessories.**"

We expressly deny any power or authority on the part of any person to incur or assume for us any other liability in connection with the sale of any hot tub or stove. This warranty does not extend to damage resulting from: assembly, improper chemical maintenance of water in the hot tub; disassembly and re-assembly of the hot tub; repair or alteration of stoves or hot tubs outside our factory in any way so as to affect its use and operation; misuse, negligence or accident; or operation contrary to printed instructions.

Products made by other manufacturers are covered under the warranties issued by those manufacturers.

WARRANTY CLAIM PROCEDURE

Hot tubs, stoves and accessories may not be returned without prior authorization from The Snorkel Stove Company. Warranty claims should be made by directly notifying The Snorkel Stove Company in writing to the address below, and/or by telephoning one of the numbers listed.

Disclaimers: There are no other warranties expressed or implied unless stated herein.

Snorkel Hot Tubs, Inc.
4216 6th Ave S. Seattle WA 98108
(800) 962-6208 (206) 340-0981 (206) 340-0982 Fax
www.snorkel.com